

DEWALT®

www.DEWALT.com

D25893

Fig. A

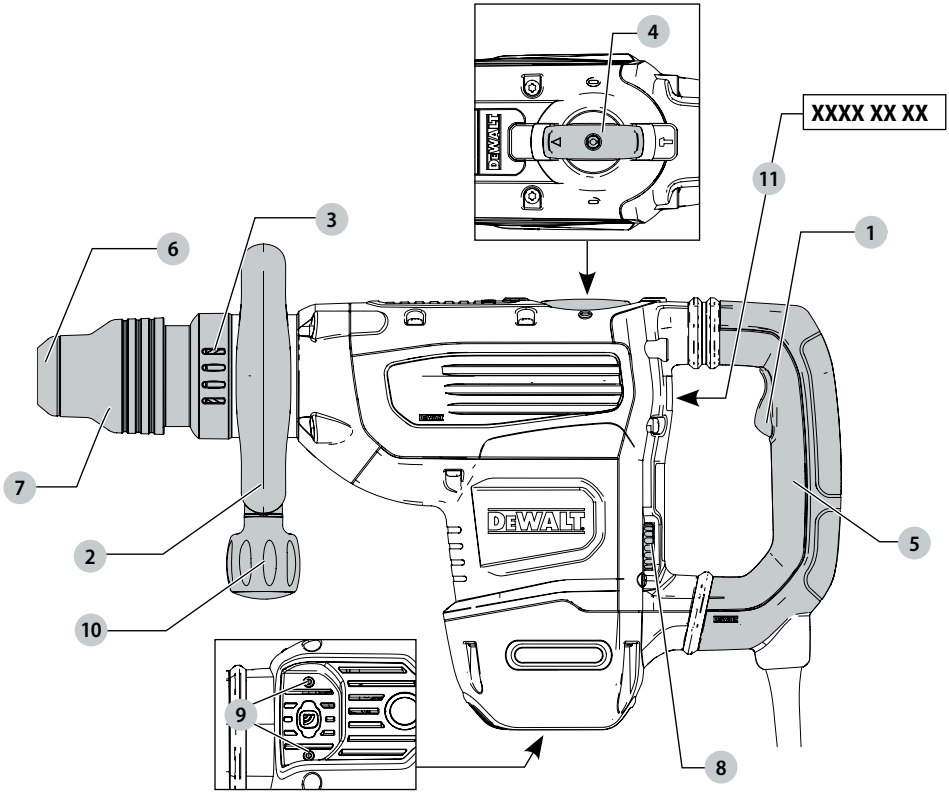

Fig. B

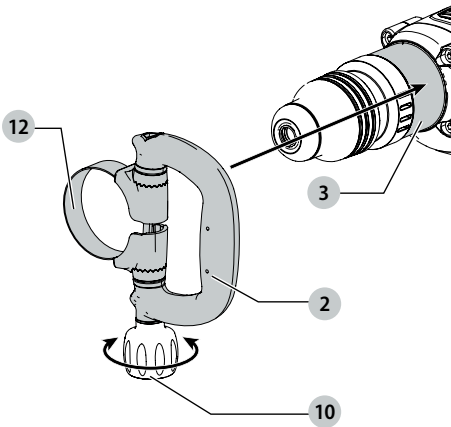

Fig. C

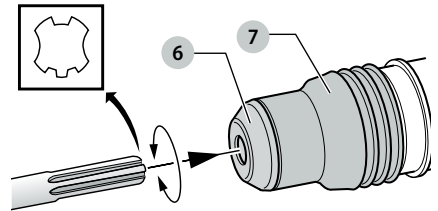

Fig. D

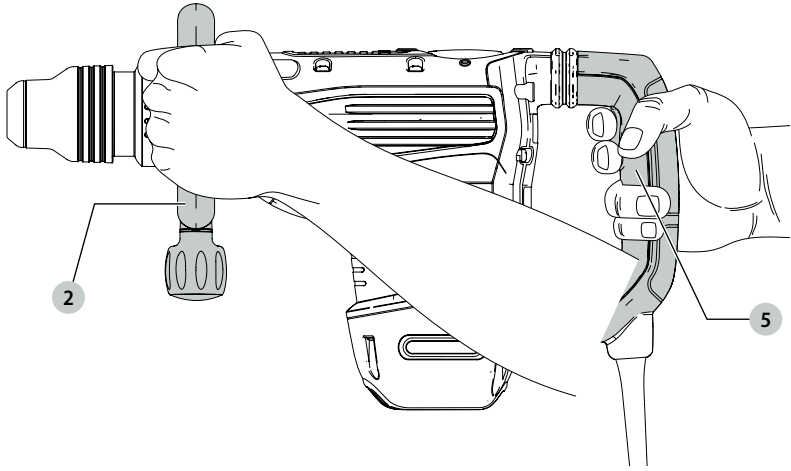
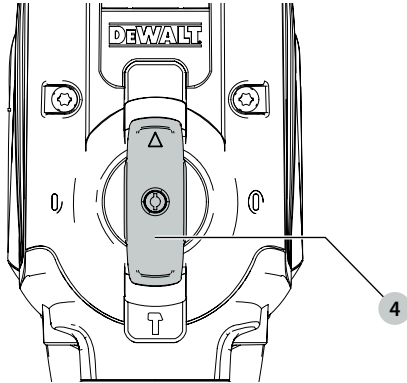

Fig. E



HEAVY-DUTY CHIPPING HAMMER

D25893

Congratulations!

You have chosen a DEWALT tool. Years of experience, thorough product development and innovation make DEWALT one of the most reliable partners for professional power tool users.

Technical Data

| | | D25893 |
|-------------------------------------|-----------------|-----------|
| Voltage | V _{AC} | 220-240 |
| Frequency | Hz | 50/60 |
| Power Input | W | 1700 |
| No-load beats per minute | bpm | 1105–2210 |
| Single impact energy (EPTA 05/2009) | J | 19.4 |
| Max. Impact Joule | J | 22.7 |
| Tool holder | | SDS MAX |
| Weight (including handle) | kg | 10.0 |



WARNING: To reduce the risk of injury, read the instruction manual.

Definitions: Safety Guidelines

The definitions below describe the level of severity for each signal word. Please read the manual and pay attention to these symbols.



DANGER: Indicates an imminently hazardous situation which, if not avoided, **will** result in **death or serious injury**.



WARNING: Indicates a potentially hazardous situation which, if not avoided, **could** result in **death or serious injury**.



CAUTION: Indicates a potentially hazardous situation which, if not avoided, **may** result in **minor or moderate injury**.

NOTICE: Indicates a practice **not related to personal injury** which, if not avoided, **may** result in **property damage**.



Denotes risk of electric shock.



Denotes risk of fire.

GENERAL POWER TOOL SAFETY WARNINGS



WARNING: Read all safety warnings, instructions, illustrations and specifications provided with this power tool. Failure to follow all instructions listed below may result in electric shock, fire and/or serious injury.

SAVE ALL WARNINGS AND INSTRUCTIONS FOR FUTURE REFERENCE.

The term “power tool” in the warnings refers to your mains-operated (corded) power tool or battery-operated (cordless) power tool.

1) Work Area Safety

- Keep work area clean and well lit.** Cluttered or dark areas invite accidents.
- Do not operate power tools in explosive atmospheres, such as in the presence of flammable liquids, gases or dust.** Power tools create sparks which may ignite the dust or fumes.
- Keep children and bystanders away while operating a power tool.** Distractions can cause you to lose control.

2) Electrical Safety

- Power tool plugs must match the outlet. Never modify the plug in any way. Do not use any adapter plugs with earthed (grounded) power tools.** Unmodified plugs and matching outlets will reduce risk of electric shock.
- Avoid body contact with earthed or grounded surfaces, such as pipes, radiators, ranges and refrigerators.** There is an increased risk of electric shock if your body is earthed or grounded.
- Do not expose power tools to rain or wet conditions.** Water entering a power tool will increase the risk of electric shock.
- Do not abuse the cord. Never use the cord for carrying, pulling or unplugging the power tool. Keep cord away from heat, oil, sharp edges or moving parts.** Damaged or entangled cords increase the risk of electric shock.
- When operating a power tool outdoors, use an extension cord suitable for outdoor use.** Use of a cord suitable for outdoor use reduces the risk of electric shock.
- If operating a power tool in a damp location is unavoidable, use a residual current device (RCD) protected supply.** Use of an RCD reduces the risk of electric shock.

3) Personal Safety

- Stay alert, watch what you are doing and use common sense when operating a power tool. Do not use a power tool while you are tired or under the influence of drugs, alcohol or medication.** A moment of inattention while operating power tools may result in serious personal injury.

- b) **Use personal protective equipment. Always wear eye protection.** Protective equipment such as a dust mask, non-skid safety shoes, hard hat or hearing protection used for appropriate conditions will reduce personal injuries.
- c) **Prevent unintentional starting. Ensure the switch is in the off-position before connecting to power source and/or battery pack, picking up or carrying the tool.** Carrying power tools with your finger on the switch or energising power tools that have the switch on invites accidents.
- d) **Remove any adjusting key or wrench before turning the power tool on.** A wrench or a key left attached to a rotating part of the power tool may result in personal injury.
- e) **Do not overreach. Keep proper footing and balance at all times.** This enables better control of the power tool in unexpected situations.
- f) **Dress properly. Do not wear loose clothing or jewellery. Keep your hair and clothing away from moving parts.** Loose clothes, jewellery or long hair can be caught in moving parts.
- g) **If devices are provided for the connection of dust extraction and collection facilities, ensure these are connected and properly used.** Use of dust collection can reduce dust-related hazards.
- h) **Do not let familiarity gained from frequent use of tools allow you to become complacent and ignore tool safety principles.** A careless action can cause severe injury within a fraction of a second.

4) Power Tool Use and Care

- a) **Do not force the power tool. Use the correct power tool for your application.** The correct power tool will do the job better and safer at the rate for which it was designed.
- b) **Do not use the power tool if the switch does not turn it on and off.** Any power tool that cannot be controlled with the switch is dangerous and must be repaired.
- c) **Disconnect the plug from the power source and/or remove the battery pack, if detachable, from the power tool before making any adjustments, changing accessories, or storing power tools.** Such preventive safety measures reduce the risk of starting the power tool accidentally.
- d) **Store idle power tools out of the reach of children and do not allow persons unfamiliar with the power tool or these instructions to operate the power tool.** Power tools are dangerous in the hands of untrained users.
- e) **Maintain power tools and accessories. Check for misalignment or binding of moving parts, breakage of parts and any other condition that may affect the power tool's operation. If damaged, have the power tool repaired before use.** Many accidents are caused by poorly maintained power tools.
- f) **Keep cutting tools sharp and clean.** Properly maintained cutting tools with sharp cutting edges are less likely to bind and are easier to control.

- g) **Use the power tool, accessories and tool bits etc. in accordance with these instructions, taking into account the working conditions and the work to be performed.** Use of the power tool for operations different from those intended could result in a hazardous situation.
- h) **Keep handles and grasping surfaces dry, clean and free from oil and grease.** Slippery handles and grasping surfaces do not allow for safe handling and control of the tool in unexpected situations.

5) Service

- a) **Have your power tool serviced by a qualified repair person using only identical replacement parts.** This will ensure that the safety of the power tool is maintained.

Additional Safety Instructions for Chipping Hammers

- **Wear ear protectors.** Exposure to noise can cause hearing loss.
- **Use auxiliary handle supplied with the tool.** Loss of control can cause personal injury.
- **Hold power tool by insulated gripping surfaces, when performing an operation where the cutting accessory may contact hidden wiring or its own cord.** Cutting accessory contacting a "live" wire may make exposed metal parts of the power tool "live" and could give the operator an electric shock.
- **Use clamps or other practical way to secure and support the workpiece to a stable platform.** Holding the work by hand or against your body is unstable and may lead to loss of control.
- **Wear safety goggles or other eye protection.** Hammering operations cause chips to fly. Flying particles can cause permanent eye damage. Wear a dust mask or respirator for applications that generate dust. Ear protection may be required for most applications.
- **Keep a firm grip on the tool at all times.** Do not attempt to operate this tool without holding it with both hands. It is recommended that the side handle be used at all times. Operating this tool with one hand will result in loss of control. Breaking through or encountering hard materials such as re-bar may be hazardous as well. Tighten the side handle securely before use.
- **Do not operate this tool for long periods of time.** Vibration caused by hammer action may be harmful to your hands and arms. Use gloves to provide extra cushion and limit exposure by taking frequent rest periods.
- **Do not recondition bits yourself.** Chisel reconditioning should be done by an authorized specialist. Improperly reconditioned chisels could cause injury.
- **Wear gloves when operating tool or changing bits.** Accessible metal parts on the tool and bits may get extremely hot during operation. Small bits of broken material may damage bare hands.
- **Never lay the tool down until the bit has come to a complete stop.** Moving bits could cause injury.

- **Do not strike jammed bits with a hammer to dislodge them.** Fragments of metal or material chips could dislodge and cause injury.
- **Slightly worn chisels can be resharpened by grinding.**
- **Keep the power cord away from the bit.** Do not wrap the cord around any part of your body. An electric cord wrapped around a spinning bit may cause personal injury and loss of control.

 **WARNING:** We recommend the use of a residual current device with a residual current rating of 30mA or less.

Residual Risks

In spite of the application of the relevant safety regulations and the implementation of safety devices, certain residual risks cannot be avoided. These are:

- Impairment of hearing.
- Risk of personal injury due to flying particles.
- Risk of burns due to accessories becoming hot during operation.
- Risk of personal injury due to prolonged use.

SAVE THESE INSTRUCTIONS

Electrical Safety

The electric motor has been designed for one voltage only. Always check that the power supply corresponds to the voltage on the rating plate.



Your DEWALT tool is double insulated in accordance with IEC60745; therefore no earth wire is required.

If the supply cord is damaged, it must be replaced only by DEWALT or an authorised service organisation.



WARNING: No connection is to be made to the earth terminal.

Follow the fitting instructions supplied with good quality plugs. Recommended fuse: 13 A.

Using an Extension Cable

If an extension cable is required, use an approved 3-core extension cable suitable for the power input of this tool (see **Technical Data**). The minimum conductor size is 1.5 mm²; the maximum length is 30 m.

When using a cable reel, always unwind the cable completely.

Package Contents

The package contains:

- 1 Chipping hammer
- 1 Side handle
- 1 chisel
- 1 Instruction manual
- Check for damage to the tool, parts or accessories which may have occurred during transport.
- Take the time to thoroughly read and understand this manual prior to operation.

Markings on Tool

The following pictograms are shown on the tool:



Read instruction manual before use.



Wear ear protection.



Wear eye protection.

Date Code Position (Fig. A)

The date code **11**, which also includes the year of manufacture, is printed into the housing.

Example:

2020 XX XX

Year of Manufacture

Description (Fig. A)



WARNING: Never modify the power tool or any part of it. Damage or personal injury could result.

- | | |
|-------------------------|--|
| 1 ON/OFF rocker switch | 8 Electronic speed and impact control dial |
| 2 Side handle | 9 DEWALT tool tag mounting holes |
| 3 Front Barrel (Collar) | 10 Screw for side handle mounting |
| 4 Mode selector dial | 11 Date code |
| 5 Main handle | |
| 6 Tool holder | |
| 7 Locking sleeve | |

Intended Use

Your chipping hammer has been designed for professional chiseling and chipping applications.

DO NOT use under wet conditions or in the presence of flammable liquids or gases.

Your chipping hammer is a professional power tool.

DO NOT let children come into contact with the tool.

Supervision is required when inexperienced operators use this tool.

- **Young children and the infirm.** This appliance is not intended for use by young children or infirm persons without supervision.
- This product is not intended for use by persons (including children) suffering from diminished physical, sensory or

mental abilities; lack of experience, knowledge or skills unless they are supervised by a person responsible for their safety. Children should never be left alone with this product.

Active Vibration Control (AVC) System

For best vibration control, hold the tool as described in **Proper Hand Position** and apply just enough pressure so the damping device on the main handle is approximately mid stroke.

The active vibration control neutralises rebound vibration from the hammer mechanism. Lowering hand and arm vibration, it allows more comfortable use for longer periods of time and extends the life of the unit.

The hammer only needs enough pressure to engage the active vibration control. Applying too much pressure will not make the tool chip faster and active vibration control will not engage.

DEWALT Tool Tag Ready (Fig. A)

Optional Accessory

Your hammer comes with DEWALT tool tag mounting holes **9** and fasteners for installing a DEWALT Tool Tag. You will need a T20 bit tip to install the tag. The DEWALT Tool Tag is designed for tracking and locating professional power tools, equipment, and machines using the DEWALT Tool Connect™ app. For proper installation of the DEWALT Tool Tag refer to the DEWALT Tool Tag manual.

Electronic Speed and Impact Control (Fig. A)

The electronic speed and impact control allows optimal tool control for precise chiseling.

To set the electronic speed and impact control dial **8**, turn the dial to the desired level. The higher the number, the greater the speed and impact energy. Dial settings make the tool extremely flexible and adaptable for many different applications. The required setting depends on the bit size and hardness of material being chiseled.

- When chiselling soft, brittle materials or when minimum break-out is required, set the dial to a low setting;
- When breaking harder materials, set the dial to a high setting.

ASSEMBLY AND ADJUSTMENTS

 **WARNING: To reduce the risk of serious personal injury, turn tool off and disconnect tool from power source before making any adjustments or removing/installing attachments or accessories. An accidental start-up can cause injury.**

Side Handle (Fig. B)

 **WARNING: To reduce the risk of personal injury, ALWAYS operate the tool with the side handle properly installed. Failure to do so may result in the side handle slipping during tool operation and subsequent loss of control. Hold tool with both hands to maximize control.**

The side handle **2** clamps to the front of the gear case and may be rotated 360° to permit right- or left-hand use.

Mounting the Side Handle Assembly (Fig. B)

1. Widen the ring opening **12** of the side handle **2** by rotating the screw for side handle mounting **10** anti-clockwise.
2. Slide the assembly onto the nose of the tool, through the steel ring **12** and onto the collar **3**, past the chisel holder and sleeve.
3. Rotate the side handle assembly to the desired position.
4. Lock the side handle mounting assembly in place by securely tightening the screw for side handle mounting **10** rotating it clockwise so that the assembly will not rotate.

Bit and Bit Holder

 **WARNING: Burn Hazard. ALWAYS wear gloves when changing bits. Accessible metal parts on the tool and bits may get extremely hot during operation. Small bits of broken material may damage bare hands.**

 **WARNING: Do not attempt to tighten or loosen chisel bits (or any other accessory) by gripping the front part of the chuck and turning the tool on. Damage to the chuck and personal injury may occur.**

The chipping hammer can be fitted with various chisel bits depending on the desired application. **Use sharp bits only.**

Inserting and Removing SDS MAX Bits (Fig. C)

NOTE: Accessories and attachments used must be lubricated around the SDS fitment before installation.

1. Pull back the locking sleeve **7** and insert the bit shank. The bit shank must be clean.
2. Turn the bit slightly until the sleeve snaps back into position.
3. Ensure the bit is properly engaged.

NOTE: The bit needs to move several centimeters in and out of the tool holder **6** when properly engaged.
4. To remove the bit, pull back the locking sleeve and pull the bit out.

Bit Position Adjustment

Turn the mode selector to bit adjustment icon (Refer to **Mode Selection**) to adjust the chisel to the desired position. There are multiple positions to set the angle of the chisel.

NOTE: After finding the desired position, slightly maneuver the chisel bit back and forth to ensure the chisel is properly engaged.

OPERATION

Instructions for Use

 **WARNING: Always observe the safety instructions and applicable regulations.**

 **WARNING: To reduce the risk of serious personal injury, turn tool off and disconnect tool from power source before making any adjustments or removing/installing attachments or accessories. An accidental start-up can cause injury.**

Proper Hand Position (Fig. D)

 **WARNING:** To reduce the risk of serious personal injury, **ALWAYS** use proper hand position as shown.



 **WARNING:** To reduce the risk of serious personal injury, **ALWAYS** hold securely in anticipation of a sudden reaction.

Proper hand position requires one hand on the mounted side handle **2**, with the other hand on the main handle **5**.

Mode Selection (Fig. E)

 **WARNING:** Do not select the operating mode when the tool is running. Tool must come to a complete stop before activating the mode selector button or damage to the tool may result.

Your tool is equipped with a mode selector dial **4** to select the mode appropriate to desired operation.

| Symbol | Mode | Application |
|--|--------------------|--|
|  | Bit Adjustment | Chisel bit position adjustment |
|  | Hammering/Chipping | Light chipping, chiseling and demolition |

To Select a Mode

- Rotate the mode selector dial so that the arrow points to the symbol corresponding for the desired mode.

NOTE: The arrow on the mode selector dial **4** must be pointing at a mode symbol at all times. There are no operable positions in between.

Indexing the Chisel Position (Fig. E)

The chisel can be indexed and locked into 24 different positions.

1. Rotate the mode selector switch **4** until it points towards the  position.
2. Rotate the chisel in the desired position.
3. Set the mode selector switch **4** to the “Hammering/Chipping” position.
4. Twist the chisel until it locks in position.

Performing an Application (Fig. A, E)

 **WARNING: TO REDUCE THE RISK OF PERSONAL INJURY, ALWAYS** ensure workpiece is anchored or clamped firmly.

NOTE: Operating temperature of this tool is 7 to +40 °C. Using the tool outside of this temperature range will decrease the life of the tool.

1. Insert the appropriate chisel and rotate it by hand to lock it into the desired position. Refer to **Bit and Bit Holder**.
2. Using the mode selector dial **4**, select chipping mode. Refer to **Mode Selection**.
3. Adjust the side handle **2** as necessary. Refer to **Mounting the Side Handle Assembly**.
4. Place the chisel on the desired location.
5. Depress the ON/OFF rocker switch **1**.
6. To stop the hammer, release the ON/OFF rocker switch.

MAINTENANCE

Your power tool has been designed to operate over a long period of time with a minimum of maintenance. Continuous satisfactory operation depends upon proper tool care and regular cleaning.

 **WARNING:** To reduce the risk of serious personal injury, **turn tool off and disconnect tool from power source before making any adjustments or removing/installing attachments or accessories.** An accidental start-up can cause injury.





Lubrication

Your power tool requires no additional lubrication.



Cleaning

 **WARNING:** Blow dirt and dust out of the main housing with dry air as often as dirt is seen collecting in and around the air vents. Wear approved eye protection and approved dust mask when performing this procedure.

 **WARNING:** Never use solvents or other harsh chemicals for cleaning the non-metallic parts of the tool. These chemicals may weaken the materials used in these parts. Use a cloth dampened only with water and mild soap. Never let any liquid get inside the tool; never immerse any part of the tool into a liquid.

Optional Accessories

 **WARNING:** Since accessories, other than those offered by DEWALT, have not been tested with this product, use of such accessories with this tool could be hazardous. To reduce the risk of injury, only DEWALT recommended accessories should be used with this product.

Consult your dealer for further information on the appropriate accessories.

Protecting the Environment



Separate collection. Products marked with this symbol must not be disposed of with normal household waste.

Products contain materials that can be recovered or recycled reducing the demand for raw materials.

Please recycle electrical products according to local provisions. Further information is available at www.2helpU.com.

After Service and Repair

DEWALT service centers are staffed with trained personnel to provide customers with efficient and reliable product service.

We do not take any responsibility when you have repaired in unauthorized service center. You can refer to the leaflet of CONTACT CENTER LOCATOR in product package and contact us through hotline, website or social media to find the nearest DEWALT service center around you.

