

DEWALT®

XR LI-ION

Ташев-Галвинг ООД
www.tashev-galving.com

www.DEWALT.com

DCS7485

Ташев-Галвинг ООД
www.tashev-galving.com

Fig. A

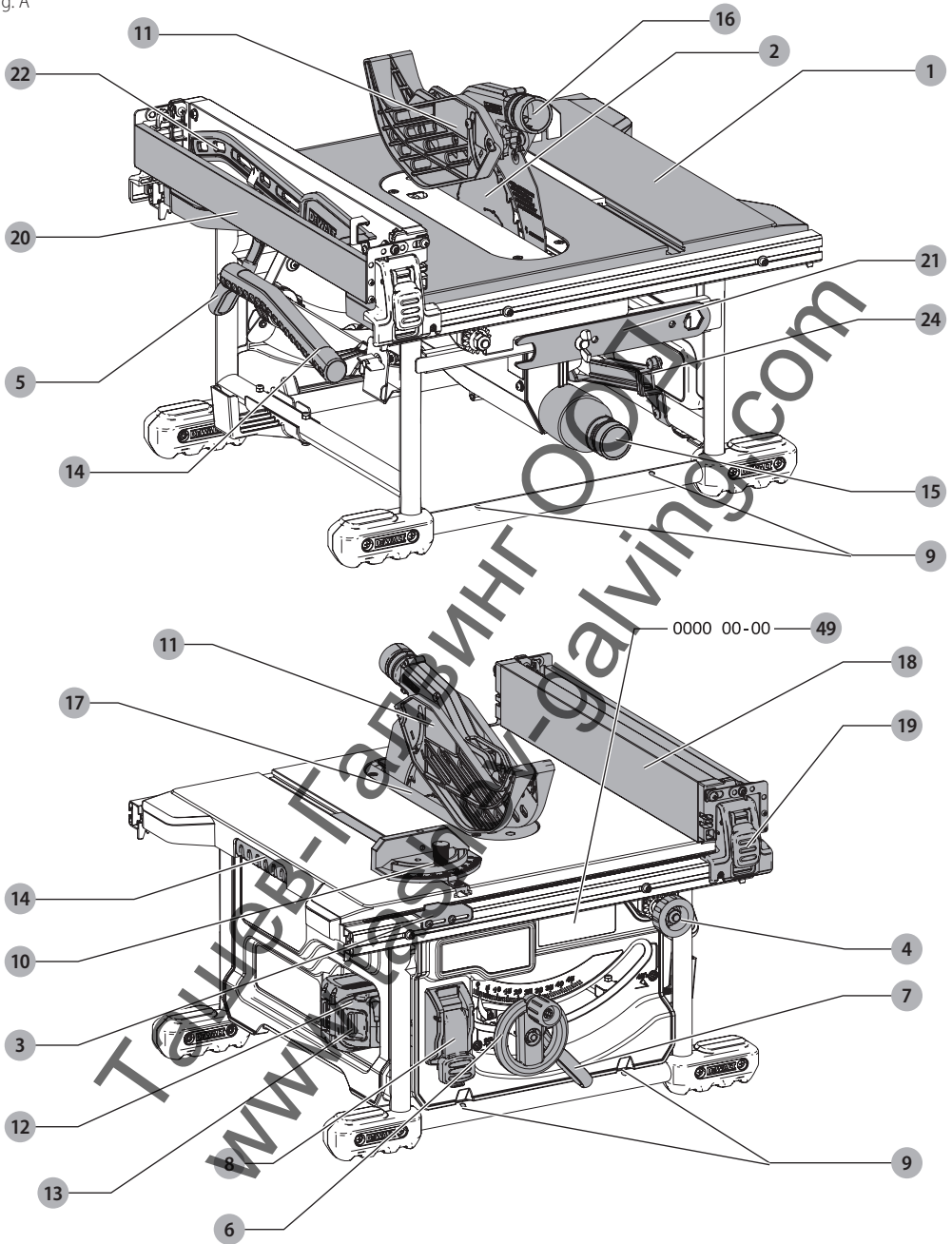

Fig. B

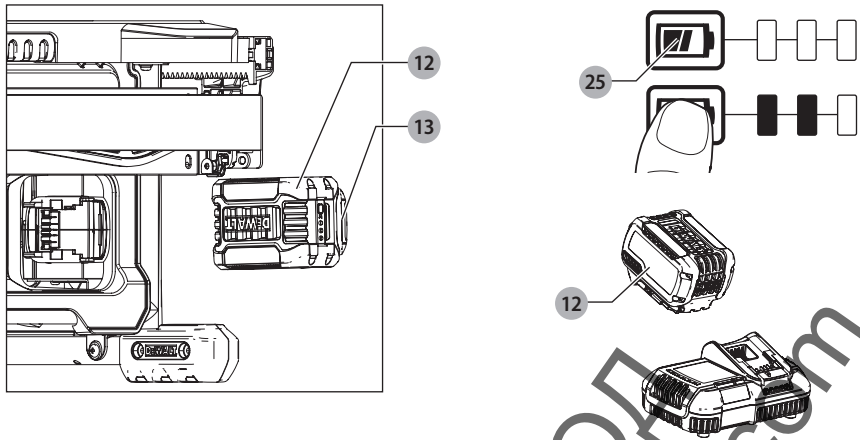

Fig. C

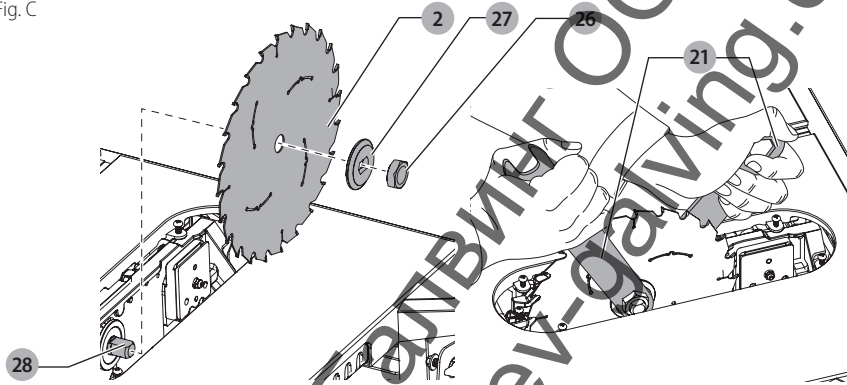

Fig. D

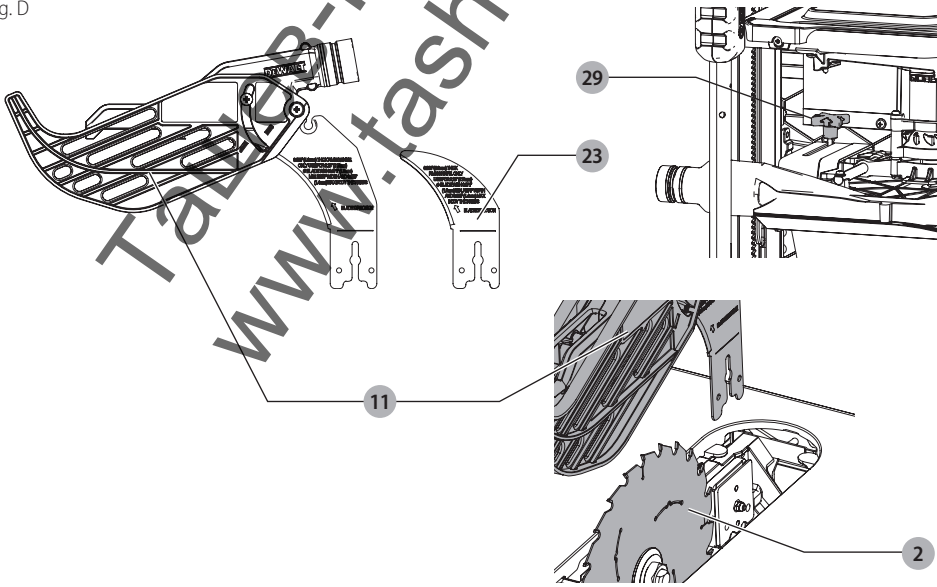

Fig. E

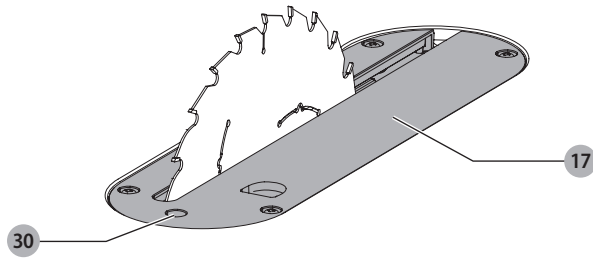

Fig. F

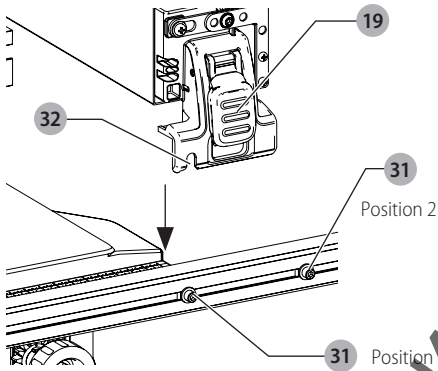

Fig. G

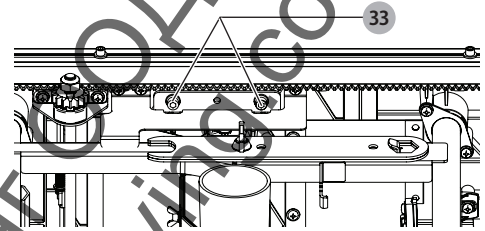

Fig. H

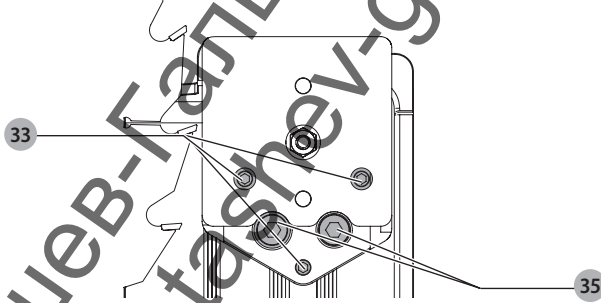

Fig. I

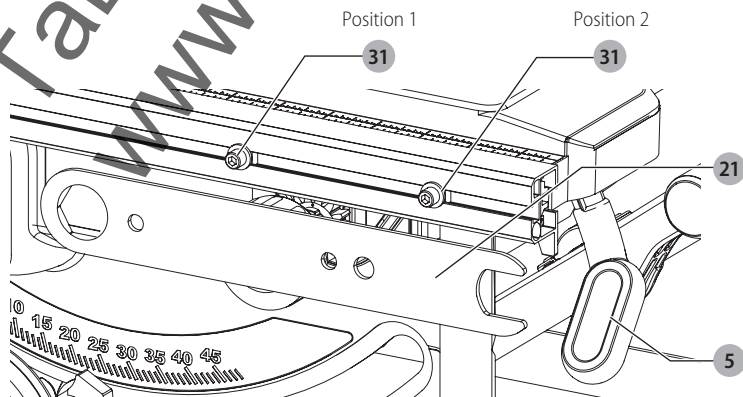

Fig. J

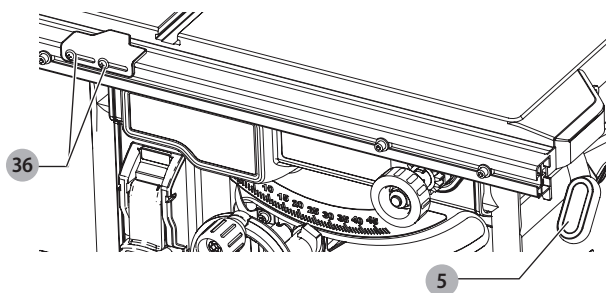

Fig. K

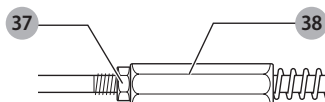

Fig. L

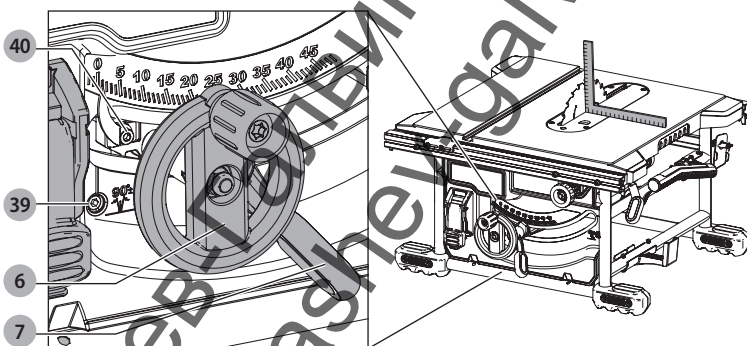

Fig. M

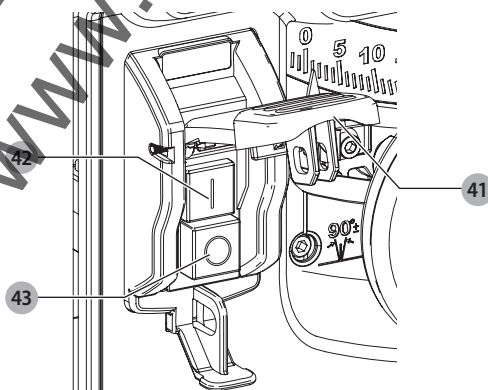

Fig. N

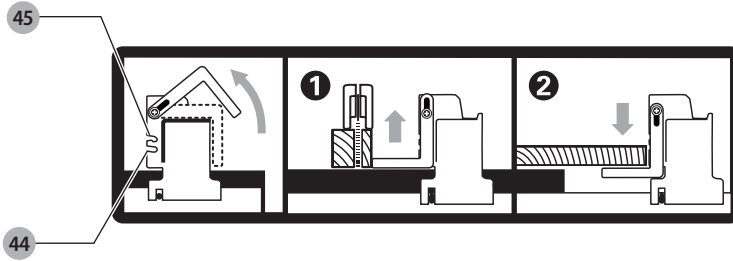

Fig. O

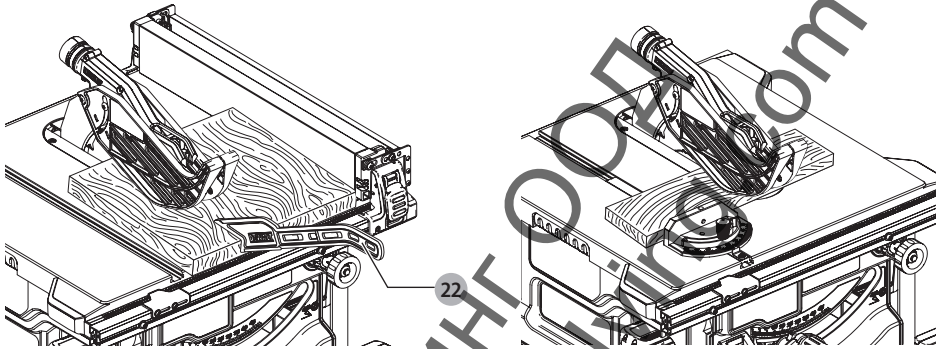

Fig. P

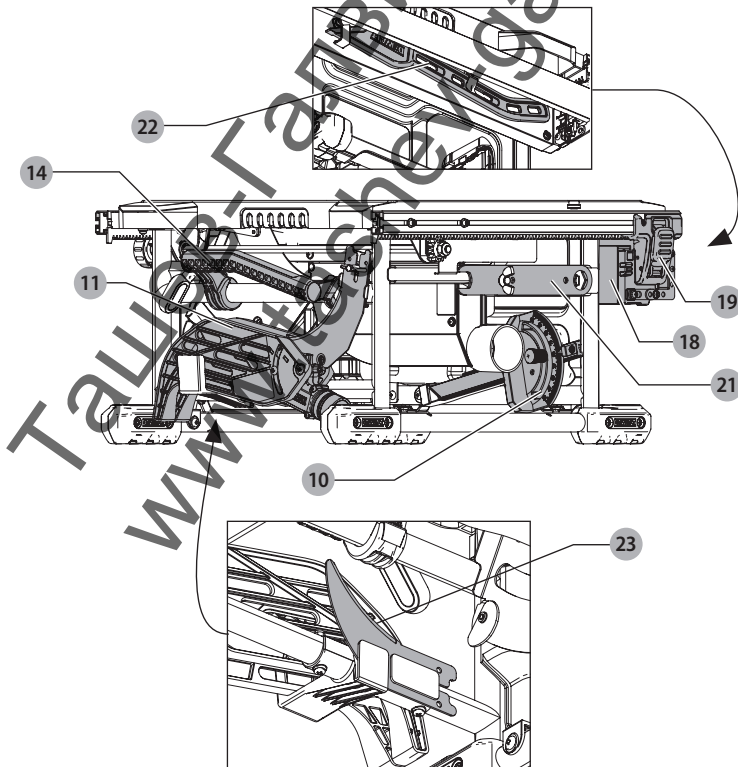

Fig. Q

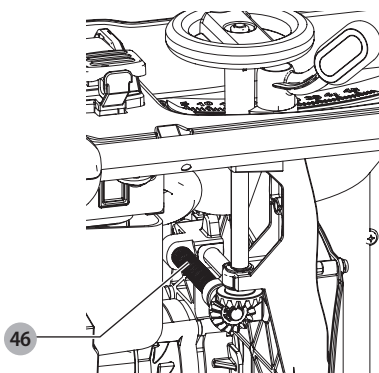
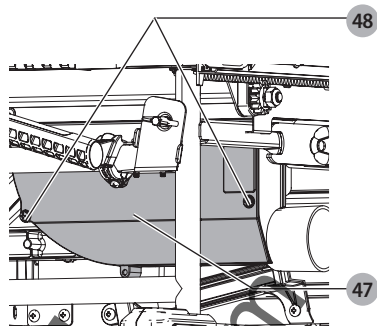

Fig. R



Ташев-Галвинг ООД
www.tashev-galving.com

CORDLESS TABLE SAW

DCS7485

Congratulations!

You have chosen a DeWALT tool. Years of experience, thorough product development and innovation make DeWALT one of the most reliable partners for professional power tool users.

Technical Data

		DCS7485
Voltage	V _{DC}	54
Type		1
Battery type		Li-Ion
No load speed	min ⁻¹	5800
Blade diameter	mm	210
Blade bore	mm	30
Blade kerf	mm	1.8
Blade body thickness	mm	1.3
Riving knife thickness	mm	1.6
Depth of cut at 90°	mm	65
Depth of cut at 45°	mm	45
Ripping capacity (Right of blade)	mm	610
Ripping capacity (Left of blade)	mm	318
Work surface dimensions	mm	485 x 485
Overall dimensions	mm	605 x 605 x 330
Weight	kg	2.15

Noise values (tri-ax vector sum) according to EN62841-1-2015:

L _{PA} (emission sound pressure level)	dB(A)	86
L _{WA} (sound power level)	dB(A)	100
K (uncertainty for the given sound level)	dB(A)	3

Battery pack	DCB546	
Battery type	Li-Ion	
Voltage	V _{DC}	18/54
Capacity	Ah	6.0(2.0)
Weight	kg	1.05

Charger	DCB118			
Mains voltage	V _{AC}	230		
Battery type	18/54 Li-Ion			
Approx. charging time of battery packs	min	22 (1.3 Ah) 45 (3.0 Ah)	22 (1.5 Ah) 60 (4.0 Ah) 60 (6.0 Ah)	30 (2.0 Ah) 75 (5.0 Ah)
Weight	kg	0,66		

The DCB118 charger accepts 18V Li-Ion XR and XR FLEXVOLT™ battery packs (DCB181, DCB182, DCB183, DCB183B, DCB184, DCB184B, DCB185 and DCB546).

Fuses:		
Europe	230V tools	10 Amperes. mains

Fuses:

U.K. & Ireland	230V tools	3 Amperes. in plugs
----------------	------------	---------------------

EC-Declaration of Conformity

Machinery Directive



Cordless Table Saw DCS7485

DeWALT declares that these products described under **Technical Data** are in compliance with: 2006/42/EC, EN62841-1:2015, EN62841-3-1:2014.

These products also comply with Directive 2014/30/EU and 2011/65/EU. For more information, please contact DeWALT at the following address or refer to the back of the manual.

The undersigned is responsible for compilation of the technical file and makes this declaration on behalf of DeWALT.

Markus Bommel

Markus Bommel
Director Engineering
DeWALT, Richard-Klinger-Straße 11,
D-65510, Idstein, Germany
29.07.2016



WARNING: To reduce the risk of injury, read the instruction manual.

Definitions: Safety Guidelines

The definitions below describe the level of severity for each signal word. Please read the manual and pay attention to these symbols.



DANGER: Indicates an imminently hazardous situation which, if not avoided, **will** result in **death or serious injury**.



WARNING: Indicates a potentially hazardous situation which, if not avoided, **could** result in **death or serious injury**.



CAUTION: Indicates a potentially hazardous situation which, if not avoided, **may** result in **minor or moderate injury**.

NOTICE: Indicates a practice **not related to personal injury** which, if not avoided, **may** result in **property damage**.



Denotes risk of electric shock.



Denotes risk of fire.

General Power Tool Safety Warnings



WARNING: Read all safety warnings, instructions, illustrations and specifications provided with this power tool. Failure to follow all instructions listed below may result in electric shock, fire and/or serious injury.

SAVE ALL WARNINGS AND INSTRUCTIONS FOR FUTURE REFERENCE

The term "power tool" in the warnings refers to your mains-operated (corded) power tool or battery-operated (cordless) power tool.

1) Work area safety

- Keep work area clean and well lit.** Cluttered or dark areas invite accidents.
- Do not operate power tools in explosive atmospheres, such as in the presence of flammable liquids, gases or dust.** Power tools create sparks which may ignite the dust or fumes.
- Keep children and bystanders away while operating a power tool.** Distractions can cause you to lose control.

2) Electrical safety

- Power tool plugs must match the outlet. Never modify the plug in any way. Do not use any adapter plugs with earthed (grounded) power tools.**
Unmodified plugs and matching outlets will reduce risk of electric shock.
- Avoid body contact with earthed or grounded surfaces such as pipes, radiators, ranges and refrigerators.** There is an increased risk of electric shock if your body is earthed or grounded.
- Do not expose power tools to rain or wet conditions.** Water entering a power tool will increase the risk of electric shock.
- Do not abuse the cord. Never use the cord for carrying, pulling or unplugging the power tool. Keep cord away from heat, oil, sharp edges or moving parts.** Damaged or entangled cords increase the risk of electric shock.
- When operating a power tool outdoors, use an extension cord suitable for outdoor use.** Use of a cord suitable for outdoor use reduces the risk of electric shock.
- If operating a power tool in a damp location is unavoidable, use a residual current device (RCD) protected supply.** Use of an RCD reduces the risk of electric shock.

3) Personal safety

- Stay alert, watch what you are doing and use common sense when operating a power tool. Do not use a power tool while you are tired or under the influence of drugs, alcohol or medication.** A moment of inattention while operating power tools may result in serious personal injury.
- Use personal protective equipment. Always wear eye protection.** Protective equipment such as dust mask,

non-skid safety shoes, hard hat, or hearing protection used for appropriate conditions will reduce personal injuries.

- Prevent unintentional starting. Ensure the switch is in the off position before connecting to power source and/or battery pack, picking up or carrying the tool.** Carrying power tools with your finger on the switch or energising power tools that have the switch on invites accidents.
- Remove any adjusting key or wrench before turning the power tool on.** A wrench or a key left attached to a rotating part of the power tool may result in personal injury.
- Do not overreach. Keep proper footing and balance at all times.** This enables better control of the power tool in unexpected situations.
- Dress properly. Do not wear loose clothing or jewellery. Keep your hair, clothing and gloves away from moving parts.** Loose clothes, jewellery or long hair can be caught in moving parts.
- If devices are provided for the connection of dust extraction and collection facilities, ensure these are connected and properly used.** Use of dust collection can reduce dust-related hazards.
- Do not let familiarity gained from frequent use of tools allow you to become complacent and ignore tool safety principles.** A careless action can cause severe injury within a fraction of a second.

4) Power tool use and care

- Do not force the power tool. Use the correct power tool for your application.** The correct power tool will do the job better and safer at the rate for which it was designed.
- Do not use the power tool if the switch does not turn it on and off.** Any power tool that cannot be controlled with the switch is dangerous and must be repaired.
- Disconnect the plug from the power source and/or remove the battery pack, if detachable, from the power tool before making any adjustments, changing accessories, or storing power tools.** Such preventive safety measures reduce the risk of starting the power tool accidentally.
- Store idle power tools out of the reach of children and do not allow persons unfamiliar with the power tool or these instructions to operate the power tool.** Power tools are dangerous in the hands of untrained users.
- Maintain power tools and accessories. Check for misalignment or binding of moving parts, breakage of parts and any other condition that may affect the power tool's operation. If damaged, have the power tool repaired before use.** Many accidents are caused by poorly maintained power tools.
- Keep cutting tools sharp and clean.** Properly maintained cutting tools with sharp cutting edges are less likely to bind and are easier to control.

- g) **Use the power tool, accessories and tool bits etc., in accordance with these instructions taking into account the working conditions and the work to be performed.** Use of the power tool for operations different from those intended could result in a hazardous situation.
- h) **Keep handles and grasping surfaces dry, clean and free from oil and grease.** Slippery handles and grasping surfaces do not allow for safe handling and control of the tool in unexpected situations.

5) Battery tool use and care

- a) **Recharge only with the charger specified by the manufacturer.** A charger that is suitable for one type of battery pack may create a risk of fire when used with another battery pack.
- b) **Use power tools only with specifically designated battery packs.** Use of any other battery packs may create a risk of injury and fire.
- c) **When battery pack is not in use, keep it away from other metal objects like paper clips, coins, keys, nails, screws or other small metal objects that can make a connection from one terminal to another.** Shorting the battery terminals together may cause burns or a fire.
- d) **Under abusive conditions, liquid may be ejected from the battery; avoid contact. If contact accidentally occurs, flush with water. If liquid contacts eyes, additionally seek medical help.** Liquid ejected from the battery may cause irritation or burns.
- e) **Do not use a battery pack or tool that is damaged or modified.** Damaged or modified batteries may exhibit unpredictable behaviour resulting in fire, explosion or risk of injury.
- f) **Do not expose a battery pack or tool to fire or excessive temperature.** Exposure to fire or temperature above 130 °C may cause explosion.
- g) **Follow all charging instructions and do not charge the battery pack or tool outside the temperature range specified in the instructions.** Charging improperly or at temperatures outside the specified range may damage the battery and increase the risk of fire.

6) Service

- a) **Have your power tool serviced by a qualified repair person using only identical replacement parts.** This will ensure that the safety of the power tool is maintained.
- b) **Never service damaged battery packs.** Service of battery packs should only be performed by the manufacturer or authorized service providers.

Safety Instructions for Table Saws

1) Guarding Related Warnings

- a) **Keep guards in place. Guards must be in working order and be properly mounted.** A guard that is loose, damaged, or is not functioning correctly must be repaired or replaced.
- b) **Always use saw blade guard, riving knife for every through-cutting operation.** For through-cutting operations where the saw blade cuts completely through the thickness of the workpiece, the guard and other safety devices help reduce the risk of injury.
- c) **Immediately reattach the guarding system after completing an operation (such as rabbeting or resawing cuts) which requires removal of the guard or riving knife.** The guard and riving knife help to reduce the risk of injury.
- d) **Make sure the saw blade is not contacting the guard, riving knife or the workpiece before the switch is turned on.** Inadvertent contact of these items with the saw blade could cause a hazardous condition.
- e) **Adjust the riving knife as described in this instruction manual.** Incorrect spacing, positioning and alignment can make the riving knife ineffective in reducing the likelihood of kickback.
- f) **For the riving knife to work, they must be engaged in the workpiece.** The riving knife is ineffective when cutting workpieces that are too short to be engaged with the riving knife. Under these conditions a kickback cannot be prevented by the riving knife.
- g) **Use the appropriate saw blade for the riving knife.** For the riving knife to function properly, the saw blade diameter must match the appropriate riving knife and the body of the saw blade must be thinner than the thickness of the riving knife and the cutting width of the saw blade must be wider than the thickness of the riving knife.

2) Cutting Procedures Warnings

- a)  **DANGER: Never place your fingers or hands in the vicinity or in line with the saw blade.**
A moment of inattention or a slip could direct your hand towards the saw blade and result in serious personal injury.
- b) **Feed the workpiece into the saw blade only against the direction of rotation.** Feeding the workpiece in the same direction that the saw blade is rotating above the table may result in the workpiece, and your hand, being pulled into the saw blade.
- c) **Never use the mitre gauge to feed the workpiece when ripping and do not use the rip fence as a length stop when cross cutting with the mitre gauge.** Guiding the workpiece with the rip fence and the mitre gauge at the same time increases the likelihood of saw blade binding and kickback.
- d) **When ripping, always apply the workpiece feeding force between the fence and the saw blade. Use a push stick when the distance between the fence and the saw blade is less than 150 mm, and use a push block when this distance is less than 50 mm.** "Work helping" devices will keep your hand at a safe distance from the saw blade.
- e) **Use only the push stick provided by the manufacturer or constructed in accordance with the**

instructions. This push stick provides sufficient distance of the hand from the saw blade.

- f) **Never use a damaged or cut push stick.** A damaged push stick may break causing your hand to slip into the saw blade.
- g) **Do not perform any operation “freehand”.** Always use either the rip fence or the mitre gauge to position and guide the workpiece. “Freehand” means using your hands to support or guide the workpiece, in lieu of a rip fence or mitre gauge. Freehand sawing leads to misalignment, binding and kickback.
- h) **Never reach around or over a rotating saw blade.** Reaching for a workpiece may lead to accidental contact with the moving saw blade.
- i) **Provide auxiliary workpiece support to the rear and/or sides of the saw table for long and/or wide workpieces to keep them level.** A long and/or wide workpiece has a tendency to pivot on the table’s edge, causing loss of control, saw blade binding and kickback.
- j) **Feed workpiece at an even pace. Do not bend or twist the workpiece. If jamming occurs, turn the tool off immediately, unplug the tool then clear the jam.** Jamming the saw blade by the workpiece can cause kickback or stall the motor.
- k) **Do not remove pieces of cut-off material while the saw is running.** The material may become trapped between the fence or inside the saw blade guard and the saw blade pulling your fingers into the saw blade. Turn the saw off and wait until the saw blade stops before removing material.
- l) **Use an auxiliary fence in contact with the table top when ripping workpieces less than 2 mm thick.** A thin workpiece may wedge under the rip fence and create a kickback.

3) Kickback Causes and Related Warnings

Kickback is a sudden reaction of the workpiece due to a pinched, jammed saw blade or misaligned line of cut in the workpiece with respect to the saw blade or when a part of the workpiece binds between the saw blade and the rip fence or other fixed object.

Most frequently during kickback, the workpiece is lifted from the table by the rear portion of the saw blade and is propelled towards the operator. Kickback is the result of saw misuse and/or incorrect operating procedures or conditions and can be avoided by taking proper precautions as given below.

- a) **Never stand directly in line with the saw blade.** Always position your body on the same side of the saw blade as the fence. Kickback may propel the workpiece at high velocity towards anyone standing in front and in line with the saw blade.
- b) **Never reach over or in back of the saw blade to pull or to support the workpiece.** Accidental contact with the saw blade may occur or kickback may drag your fingers into the saw blade.
- c) **Never hold and press the workpiece that is being cut off against the rotating saw blade.** Pressing the

workpiece being cut off against the saw blade will create a binding condition and kickback.

- d) **Align the fence to be parallel with the saw blade.** A misaligned fence will pinch the workpiece against the saw blade and create kickback.
- e) **Use a featherboard to guide the workpiece against the table and fence when making non-through cuts such as rabbeting or resawing cuts.** A featherboard helps to control the workpiece in the event of a kickback.
- f) **Use extra caution when making a cut into blind areas of assembled workpieces.** The protruding saw blade may cut objects that can cause kickback.
- g) **Support large panels to minimise the risk of saw blade pinching and kickback.** Large panels tend to sag under their own weight. Support(s) must be placed under all portions of the panel overhanging the table top.
- h) **Use extra caution when cutting a workpiece that is twisted, knotted, warped or does not have a straight edge to guide it with a mitre gauge or along the fence.** A warped, knotted or twisted workpiece is unstable and causes misalignment of the kerf with the saw blade, binding and kickback.
- i) **Never cut more than one workpiece, stacked vertically or horizontally.** The saw blade could pick up one or more pieces and cause kickback.
- j) **When restarting the saw with the saw blade in the workpiece, centre the saw blade in the kerf so that the saw teeth are not engaged in the material.** If the saw blade binds, it may lift up the workpiece and cause kickback when the saw is restarted.
- k) **Keep saw blades clean, sharp, and with sufficient set. Never use warped saw blades or saw blades with cracked or broken teeth.** Sharp and properly set saw blades minimise binding, stalling and kickback.

4) Table Saw Operating Procedure Warnings

- a) **Turn off the table saw and disconnect the battery pack when removing the table insert, changing the saw blade or making adjustments to the riving knife, or blade guard, and when the machine is left unattended.** Precautionary measures will avoid accidents.
- b) **Never leave the table saw running unattended.** Turn it off and don’t leave the tool until it comes to a complete stop. An unattended running saw is an uncontrolled hazard.
- c) **Locate the table saw in a well-lit and level area where you can maintain good footing and balance. It should be installed in an area that provides enough room to easily handle the size of your workpiece.** Cramped, dark areas, and uneven slippery floors invite accidents.
- d) **Frequently clean and remove sawdust from under the saw table and/or the dust collection device.** Accumulated sawdust is combustible and may self-ignite.

- e) **The table saw must be secured.** A table saw that is not properly secured may move or tip over.
- f) **Remove tools, wood scraps, etc. from the table before the table saw is turned on.** Distraction or a potential jam can be dangerous.
- g) **Always use saw blades with correct size and shape (diamond versus round) of arbour holes.** Saw blades that do not match the mounting hardware of the saw will run off-centre, causing loss of control.
- h) **Never use damaged or incorrect saw blade mounting means such as flanges, saw blade washers, bolts or nuts.** These mounting means were specially designed for your saw, for safe operation and optimum performance.
- i) **Never stand on the table saw, do not use it as a stepping stool.** Serious injury could occur if the tool is tipped or if the cutting tool is accidentally contacted.
- j) **Make sure that the saw blade is installed to rotate in the proper direction. Do not use grinding wheels, wire brushes, or abrasive wheels on a table saw.** Improper saw blade installation or use of accessories not recommended may cause serious injury.

Additional Safety Rules for Saw Benches



WARNING: Cutting plastics, sap coated wood, and other materials may cause melted material to accumulate on the blade tips and the body of the saw blade, increasing the risk of blade overheating and binding while cutting.

- Make sure that the blade rotates in the correct direction and that the teeth are pointing to the front of the saw bench.
- Be sure all clamp handles are tight before starting any operation.
- Be sure all blade and flanges are clean and the larger face of the clamp washer is against the blade. Tighten the arbor nut securely.
- Make sure that the riving knife is adjusted to the correct distance from the blade - maximum 8 mm.
- Never operate the saw without the upper and lower guards in place.
- Do not apply lubricants to the blade when it is running.
- Always keep the push stick in its store place when not in use.
- Do not use the guard for handling or transportation.
- Do not exert side pressure on the saw blade.
- Never cut light alloy. The machine is not designed for this application.
- Do not use abrasive disc or diamond cutting wheels
- Rabbeting, slotting or grooving is not allowed.
- In case of machine failure, immediately switch the machine off and remove the battery. Report the failure and mark the machine in suitable form which prevents that other persons use the defective machine.
- When the saw blade is blocked due to abnormal feed force during cutting, ALWAYS switch the machine off and remove the battery. Remove the workpiece and ensure that the saw blade runs free. Turn the machine on and start a new cutting operation with reduced feed force.

- NEVER attempt to cut a stack of loose pieces of material which could cause loss of control or kickback. Support all materials securely.

Saw Blades

- Do not use saw blades that do not conform to the dimensions stated in the **Technical Data**. Do not use any spacers to make a blade fit onto the spindle. Use only the blades specified in this manual, complying with EN847-1, if intended for wood and similar materials.
- Consider applying specially designed noise-reduction blades.
- Do not use high steel (HS) saw blades.
- Do not use cracked or damaged saw blades.
- Ensure that the chosen saw blade is suitable for the material to be cut.
- Always wear gloves for handling saw blades and rough material. Saw blades should be carried in a holder wherever practicable.

Residual risks

The following risks are inherent to the use of saws:

- injuries caused by touching the rotating parts
- In spite of the application of the relevant safety regulations and the implementation of safety devices, certain residual risks cannot be avoided. These are:

- Impairment of hearing.
- Risk of accidents caused by the uncovered parts of the rotating saw blade.
- Risk of injury when changing the saw blade with unprotected hands.
- Risk of squeezing fingers when opening the guards.
- Health hazards caused by breathing dust developed when sawing wood, especially oak, beech and MDF.

The following factors are of influence to noise production:

- the material to be cut
- the type of saw blade
- the feed force
- machine maintenance

The following factors are of influence to dust exposure:

- worn saw blade
- dust extractor with air velocity less than 20 m/s
- workpiece not exactly guided

Electrical Safety

The electric motor has been designed for one voltage only. Always check that the battery pack voltage corresponds to the voltage on the rating plate. Also make sure that the voltage of your charger corresponds to that of your mains.



Your DEWALT charger is double insulated in accordance with EN60335; therefore no earth wire is required.

If the supply cord is damaged, it must be replaced by a specially prepared cord available through the DEWALT service organisation.

Mains Plug Replacement (U.K. & Ireland Only)

If a new mains plug needs to be fitted:

- Safely dispose of the old plug.
- Connect the brown lead to the live terminal in the plug.
- Connect the blue lead to the neutral terminal.



WARNING: No connection is to be made to the earth terminal.

Follow the fitting instructions supplied with good quality plugs.
Recommended fuse: 3 A.

Using an Extension Cable

An extension cord should not be used unless absolutely necessary. Use an approved extension cable suitable for the power input of your charger (see **Technical Data**). The minimum conductor size is 1 mm²; the maximum length is 30 m.

When using a cable reel, always unwind the cable completely.

SAVE THESE INSTRUCTIONS

Chargers

DEWALT chargers require no adjustment and are designed to be as easy as possible to operate.

Important Safety Instructions for All Battery Chargers

SAVE THESE INSTRUCTIONS: This manual contains important safety and operating instructions for compatible battery chargers (refer to **Technical Data**).

- Before using charger, read all instructions and cautionary markings on charger, battery pack, and product using battery pack.



WARNING: Shock hazard. Do not allow any liquid to get inside charger. Electric shock may result.



WARNING: We recommend the use of a residual current device with a residual current rating of 30mA or less.



CAUTION: Burn hazard. To reduce the risk of injury, charge only DEWALT rechargeable batteries. Other types of batteries may burst causing personal injury and damage.



CAUTION: Children should be supervised to ensure that they do not play with the appliance.

NOTICE: Under certain conditions, with the charger plugged into the power supply, the exposed charging contacts inside the charger can be shorted by foreign material. Foreign materials of a conductive nature such as, but not limited to, steel wool, aluminum foil or any buildup of metallic particles should be kept away from charger cavities. Always unplug the charger from the power supply when there is no battery pack in the cavity. Unplug charger before attempting to clean

- **DO NOT attempt to charge the battery pack with any chargers other than the ones in this manual.** The charger and battery pack are specifically designed to work together.

- **These chargers are not intended for any uses other than charging DEWALT rechargeable batteries.** Any other uses may result in risk of fire, electric shock or electrocution.

- **Do not expose charger to rain or snow.**

- **Pull by plug rather than cord when disconnecting charger.** This will reduce risk of damage to electric plug and cord.

- **Make sure that cord is located so that it will not be stepped on, tripped over, or otherwise subjected to damage or stress.**

- **Do not use an extension cord unless it is absolutely necessary.** Use of improper extension cord could result in risk of fire, electric shock, or electrocution.

- **Do not place any object on top of charger or place the charger on a soft surface that might block the ventilation slots and result in excessive internal heat.** Place the charger in a position away from any heat source. The charger is ventilated through slots in the top and the bottom of the housing.

- **Do not operate charger with damaged cord or plug—** have them replaced immediately.

- **Do not operate charger if it has received a sharp blow, been dropped, or otherwise damaged in any way.** Take it to an authorised service centre.

- **Do not disassemble charger; take it to an authorised service centre when service or repair is required.** Incorrect reassembly may result in a risk of electric shock, electrocution or fire.

- In case of damaged power supply cord the supply cord must be replaced immediately by the manufacturer, its service agent or similar qualified person to prevent any hazard.

- **Disconnect the charger from the outlet before attempting any cleaning. This will reduce the risk of electric shock.** Removing the battery pack will not reduce this risk.

- **NEVER** attempt to connect two chargers together.

- **The charger is designed to operate on standard 230V household electrical power. Do not attempt to use it on any other voltage.** This does not apply to the vehicular charger.





Charging a Battery (Fig. B)

1. Plug the charger into an appropriate outlet before inserting battery pack.
2. Insert the battery pack **12** into the charger, making sure the battery pack is fully seated in the charger. The red (charging) light will blink repeatedly indicating that the charging process has started.
3. The completion of charge will be indicated by the red light remaining ON continuously. The battery pack is fully charged and may be used at this time or left in the charger. To remove the battery pack from the charger, push the battery release button **13** on the battery pack.

NOTE: To ensure maximum performance and life of lithium-ion battery packs, charge the battery pack fully before first use.

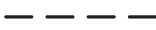
Charger Operation

Refer to the indicators below for the charge status of the battery pack.

Charge Indicators	
 Charging	
 Fully Charged	
 Hot/Cold Pack Delay*	

*The red light will continue to blink, but a yellow indicator light will be illuminated during this operation. Once the battery pack has reached an appropriate temperature, the yellow light will turn off and the charger will resume the charging procedure.

The compatible charger(s) will not charge a faulty battery pack. The charger will indicate faulty battery by refusing to light or by displaying problem pack or charger blink pattern.

NOTE: This could also mean a problem with a charger.

If the charger indicates a problem, take the charger and battery pack to be tested at an authorised service centre.

Hot/Cold Pack Delay

When the charger detects a battery pack that is too hot or too cold, it automatically starts a Hot/Cold Pack Delay, suspending charging until the battery pack has reached an appropriate temperature. The charger then automatically switches to the pack charging mode. This feature ensures maximum battery pack life.

A cold battery pack will charge at a slower rate than a warm battery pack. The battery pack will charge at that slower rate throughout the entire charging cycle and will not return to maximum charge rate even if the battery pack warms.

The DCB118 charger is equipped with an internal fan designed to cool the battery pack. The fan will turn on automatically when the battery pack needs to be cooled. Never operate the charger if the fan does not operate properly or if ventilation slots are blocked. Do not permit foreign objects to enter the interior of the charger.

Electronic Protection System

XR Li-Ion tools are designed with an Electronic Protection System that will protect the battery pack against overloading, overheating or deep discharge.

The tool will automatically turn off if the Electronic Protection System engages. If this occurs, place the lithium-ion battery pack on the charger until it is fully charged.

Wall Mounting

These chargers are designed to be wall mountable or to sit upright on a table or work surface. If wall mounting, locate the charger within reach of an electrical outlet, and away from a corner or other obstructions which may impede air flow. Use the back of the charger as a template for the location of the mounting screws on the wall. Mount the charger securely using drywall screws (purchased separately) at least 25.4 mm long with a screw head diameter of 7–9 mm, screwed into wood to an optimal depth leaving approximately 5.5 mm of the screw

exposed. Align the slots on the back of the charger with the exposed screws and fully engage them in the slots.

Charger Cleaning Instructions

⚠ WARNING: Shock hazard. Disconnect the charger from the AC outlet before cleaning. Dirt and grease may be removed from the exterior of the charger using a cloth or soft non-metallic brush. Do not use water or any cleaning solutions. Never let any liquid get inside the tool; never immerse any part of the tool into a liquid.

Battery Packs

Important Safety Instructions for All Battery Packs

When ordering replacement battery packs, be sure to include catalog number and voltage.

The battery pack is not fully charged out of the carton. Before using the battery pack and charger, read the safety instructions below. Then follow charging procedures outlined.

READ ALL INSTRUCTIONS

- **Do not charge or use battery in explosive atmospheres, such as in the presence of flammable liquids, gases or dust.** Inserting or removing the battery from the charger may ignite the dust or fumes.

Never force battery pack into charger. Do not modify battery pack in any way to fit into a non-compatible charger as battery pack may rupture causing serious personal injury.

- Charge the battery packs only in DEWALT chargers.
- **DO NOT splash or immerse in water or other liquids.**
- **Do not store or use the tool and battery pack in locations where the temperature may reach or exceed 40 °C (104 °F) (such as outside sheds or metal buildings in summer).**
- **Do not incinerate the battery pack even if it is severely damaged or is completely worn out.** The battery pack can explode in a fire. Toxic fumes and materials are created when lithium-ion battery packs are burned.
- **If battery contents come into contact with the skin, immediately wash area with mild soap and water.** If battery liquid gets into the eye, rinse water over the open eye for 15 minutes or until irritation ceases. If medical attention is needed, the battery electrolyte is composed of a mixture of liquid organic carbonates and lithium salts.
- **Contents of opened battery cells may cause respiratory irritation.** Provide fresh air. If symptoms persists, seek medical attention.

⚠ WARNING: Burn hazard. Battery liquid may be flammable if exposed to spark or flame.

⚠ WARNING: Never attempt to open the battery pack for any reason. If battery pack case is cracked or damaged, do not insert into charger. Do not crush, drop or damage battery pack. Do not use a battery pack or charger that has received a sharp blow, been dropped, run over or damaged in any way (i.e., pierced with a nail, hit with

a hammer, stepped on). Electric shock or electrocution may result. Damaged battery packs should be returned to service centre for recycling.

WARNING: Fire hazard. Do not store or carry the battery pack so that metal objects can contact exposed battery terminals. For example, do not place the battery pack in aprons, pockets, tool boxes, product kit boxes, drawers, etc., with loose nails, screws, keys, etc.

CAUTION: When not in use, place tool on its side on a stable surface where it will not cause a tripping or falling hazard. Some tools with large battery packs will stand upright on the battery pack but may be easily knocked over.

Transportation

WARNING: Fire hazard. Transporting batteries can possibly cause fire if the battery terminals inadvertently come in contact with conductive materials. When transporting batteries, make sure that the battery terminals are protected and well insulated from materials that could contact them and cause a short circuit.

DeWALT batteries comply with all applicable shipping regulations as prescribed by industry and legal standards which include UN Recommendations on the Transport of Dangerous Goods; International Air Transport Association (IATA) Dangerous Goods Regulations, International Maritime Dangerous Goods (IMDG) Regulations, and the European Agreement Concerning The International Carriage of Dangerous Goods by Road (ADR). Lithium-ion cells and batteries have been tested to section 38.3 of the UN Recommendations on the Transport of Dangerous Goods Manual of Tests and Criteria.

In most instances, shipping a DeWALT battery pack will be exempted from being classified as a fully regulated Class 9 Hazardous Material. In general, only shipments containing a lithium-ion battery with an energy rating greater than 100 Watt Hours (Wh) will require being shipped as fully regulated Class 9. All lithium-ion batteries have the Watt Hour rating marked on the pack. Furthermore, due to regulation complexities, DeWALT does not recommend air shipping lithium-ion battery packs alone regardless of Watt Hour rating. Shipments of tools with batteries (combo kits) can be air shipped as excepted if the Watt Hour rating of the battery pack is no greater than 100 Whr.

Regardless of whether a shipment is considered excepted or fully regulated, it is the shipper's responsibility to consult the latest regulations for packaging, labeling/marketing and documentation requirements.

The information provided in this section of the manual is provided in good faith and believed to be accurate at the time the document was created. However, no warranty, expressed or implied, is given. It is the buyer's responsibility to ensure that its activities comply with the applicable regulations.

Transporting the FLEXVOLT™ Battery

The DeWALT FLEXVOLT™ battery has two modes: **Use** and **Transport**.

Use Mode: When the FLEXVOLT™ battery stands alone or is in a DeWALT 18V product, it will operate as an 18V battery. When the FLEXVOLT™ battery is in a 54V or a 108V (two 54V batteries) product, it will operate as a 54V battery.

Transport Mode: When the cap is attached to the FLEXVOLT™ battery, the battery is in transport mode. Keep the cap for shipping.

When in Transport mode, strings of cells are electrically disconnected within the pack resulting in 3 batteries with a lower Watt hour (Wh) rating as compared to 1 battery with a higher Watt hour rating. This increased quantity of 3 batteries with the lower Watt hour rating can exempt the pack from certain shipping regulations that are imposed upon the higher Watt hour batteries.

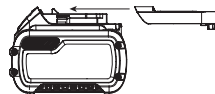

Transport Wh rating indicates 3 x 36 Wh meaning 3 batteries of 36 Watt hours each. The Use Wh rating indicates 108 Watt hours (1 battery implied).

Example of Use and Transport Label Marking



Storage Recommendations

1. The best storage place is one that is cool and dry away from direct sunlight and excess heat or cold. For optimum battery performance and life, store battery packs at room temperature when not in use.
2. For long storage, it is recommended to store a fully charged battery pack in a cool, dry place out of the charger for optimal results.

NOTE: Battery packs should not be stored completely depleted of charge. The battery pack will need to be recharged before use.

Labels on Charger and Battery Pack

In addition to the pictographs used in this manual, the labels on the charger and the battery pack may show the following pictographs:



Read instruction manual before use.



See **Technical Data** for charging time.



Do not probe with conductive objects.



Do not charge damaged battery packs.



Do not expose to water.



Have defective cords replaced immediately.



Charge only between 4 °C and 40 °C.



Only for indoor use.



Discard the battery pack with due care for the environment.

Li-Ion



Charge DeWALT battery packs only with designated DeWALT chargers. Charging battery packs other than the designated DeWALT batteries with a DeWALT charger may make them burst or lead to other dangerous situations.



Do not incinerate the battery pack.



Use: Use without transportation cap, Wh rating indicates 108 Wh (1 battery with 108 Wh).



Transport: Transport with built-in transport cap, Wh rating indicates 3 x 36 Wh (3 batteries of 36 Wh).

Battery Type

The DCS7485 operates on a 54 volt battery pack.

These battery packs may be used: DCB546. Refer to **Technical Data** for more information.

Package Contents

The package contains:

- 1 Partly assembled machine
- 1 Rip fence assembly
- 1 Mitre fence
- 1 Saw blade
- 1 Upper blade guard assembly
- 1 Throat plate
- 2 Blade wrenches
- 1 Dust extraction adapter
- 1 Battery charger (T2)
- 2 Li-Ion battery packs (2)
- 1 Instruction manual

- Check for damage to the tool, parts or accessories which may have occurred during transport.
- Take the time to thoroughly read and understand this manual prior to operation.

Markings on Tool

The following pictograms are shown on the tool:



Read instruction manual before use.



Wear ear protection.



Wear eye protection.



Wear face mask.



Keep hands away from cutting area and the blade.



Carrying point.



Remove battery when changing blade, installing/removing accessories and making adjustment/repairs.

Date Code Position (Fig. A)

The date code 49, which also includes the year of manufacture, is printed into the housing.

Example:

2016 XX XX

Year of Manufacture

Description (Fig. A, D)



WARNING: Never modify the power tool or any part of it. Damage or personal injury could result.

- | | |
|---------------------------------|--|
| 1 Table | 14 Carry handle |
| 2 Blade | 15 Dust collection port |
| 3 Rip scale indicator | 16 Guard dust collection port |
| 4 Fine adjust knob | 17 Throat plate |
| 5 Rail lock lever | 18 Rip fence |
| 6 Blade height adjustment wheel | 19 Rip fence latch |
| 7 Bevel lock lever | 20 Narrow ripping fence/support extension |
| 8 ON/OFF assembly | 21 Blade wrenches (stored position) |
| 9 Mounting holes | 22 Push stick (stored position) |
| 10 Mitre gauge | 23 Riving knife (non thru sawing) (Fig. D) |
| 11 Blade guard assembly | 24 Mitre gauge storage |
| 12 Battery | |
| 13 Battery release button | |

Intended Use

Your table saw has been designed for professional ripping, cross-cutting, mitreing and bevelling with various materials as wood analogous materials and plastic.

DO NOT use for cutting metal, cement board, or masonry.

DO NOT use under wet conditions or in presence of flammable liquids or gases.

These table saws are professional power tools.

DO NOT let children come into contact with the tool.

Supervision is required when inexperienced operators use this tool.

- **Young children and the infirm.** This appliance is not intended for use by young children or infirm persons without supervision.
- This product is not intended for use by persons (including children) suffering from diminished physical, sensory or mental abilities; lack of experience, knowledge or skills unless they are supervised by a person responsible for their safety. Children should never be left alone with this product.

ASSEMBLY AND ADJUSTMENTS

! **WARNING:** To reduce the risk of serious personal injury, turn tool off and disconnect battery pack before making any adjustments or removing/installing attachments or accessories. An accidental start-up can cause injury.

! **WARNING:** Use only DEWALT battery packs and chargers.

Inserting and Removing the Battery Pack from the Tool (Fig. B)

NOTE: Make sure your battery pack **12** is fully charged.

To Install the Battery Pack into the Machine

1. Align the battery pack with the rails inside the machine.
2. Slide it into the machine until the battery pack is firmly seated in the tool and ensure that you hear the lock snap into place.

To Remove the Battery Pack from the Machine

1. Press the release button **13** and firmly pull the battery pack out of the machine.
2. Insert battery pack into the charger as described in the charger section of this manual.

Fuel Gauge Battery Packs (Fig. B)

Some DEWALT battery packs include a fuel gauge which consists of three green LED lights that indicate the level of charge remaining in the battery pack.

To actuate the fuel gauge, press and hold the fuel gauge button **25**. A combination of the three green LED lights will illuminate designating the level of charge left. When the level of charge in the battery is below the usable limit, the fuel gauge will not illuminate and the battery will need to be recharged.

NOTE: The fuel gauge is only an indication of the charge left on the battery pack. It does not indicate tool functionality and is subject to variation based on product components, temperature and end-user application.

Unpacking

- Remove the saw from the packaging material carefully.
- The machine is fully assembled except for the rip fence, mitre gauge, dust adapter and blade guard assembly.
- Finalise the assembly following the instructions as described below.

Mounting the Saw Blade (Fig. A, C)

! **WARNING:** To reduce the risk of injury, turn unit off and disconnect machine from power source before installing and removing accessories, before adjusting or changing set-ups or when making repairs. Be sure the trigger switch is in the OFF position. An accidental start-up can cause injury.

! **WARNING:** The teeth of a new blade are very sharp and can be dangerous.

! **WARNING:** The saw blade **MUST** be replaced as described in this section. **ONLY** use saw blades as specified under Technical Data. We suggest DT99565. NEVER fit other saw blades.

NOTE: This tool has blade installed from factory.

1. Raise the saw blade arbor to its maximum height by turning the blade height adjustment wheel **6** clockwise.
2. Remove the throat plate **17**. Refer to **Mounting the throat plate**.
3. Using wrenches **21**, loosen and remove the arbor nut **26** and clamp washer **27** from the saw arbor by turning anti-clockwise.
4. Place the saw blade on to the arbor **28** making sure the teeth of the blade **2** point down at the front of the table. Assemble the washers and arbor nut to the spindle and tighten arbor nut **26** as far as possible by hand, making sure that the saw blade is against the inner washer and the outer clamp washer **27** is against the blade. Ensure the largest diameter of the flange is against the blade. Ensure the spindle and washers are free from dust and debris.
5. To keep the spindle from rotating when tightening the arbor nut, use the open end of the blade wrench **21** to secure the spindle.
6. Using the closed end of the blade wrench, tighten the arbor nut **26** by turning it clockwise.
7. Replace the throat plate.

! **WARNING:** Always check the rip fence pointer and the blade guard assembly after having changed the blade.

Mounting/Removing the Blade Guard Assembly/Riving Knife (Fig. A, D)

! **WARNING:** Use the guard assembly for all through cutting.

1. Raise the saw blade arbor to its maximum height.
2. Loosen the riving knife lock knob **29** (minimum of three turns).
3. To disengage riving knife lock pin, pull lock knob as indicated by the black arrows on the knob.
4. While pulling the lock knob, lift the riving knife out of the clamp. Then slide the blade guard assembly into the clamp until it bottoms out.

NOTE: Do not install both blade guard assembly and riving knife into the clamp at the same time.
5. Release the lock knob to engage the lock pin. Give the blade guard a slight pull upwards to ensure pin is engaged.

6. Tighten the riving knife lock knob.

NOTE: Follow the same procedure for the riving knife.

WARNING: Before connecting the table saw to the power source or operating the saw, always inspect the blade guard assembly for proper alignment and clearance with saw blade. Check alignment after each change of bevel angle.

WARNING: To reduce the risk of serious personal injury, DO NOT operate saw if blade assembly is not securely clamped in place.

When properly aligned, the riving knife **23** will be in line with the blade at both table top level, and at the top of the blade. Using a straight edge, ensure that the blade **2** is aligned with the riving knife **23**. With power disconnected, operate the blade tilt and height adjustments through the extremes of travel and insure the blade guard assembly clears the blade in all operations.

WARNING: Correct mounting and alignment of the blade guard assembly is essential to safe operation!

Mounting the Throat Plate (Fig. E)

1. Align the throat plate **17** as shown in figure E, and insert the tabs on the back of the throat plate into the holes on the back of the table opening.
2. Turn the locking screw **30** with a screw driver clockwise 90° to lock the table insert in place.
3. The throat plate includes four adjustment screws which raise or lower the throat plate. When properly adjusted, the front of the throat plate should be flush or slightly below the surface of the table top and secured in place. The rear of the throat plate should be flush or slightly above the table top.

WARNING: Never use the machine without the throat plate. Immediately replace the throat plate when worn or damaged.

Removing the Throat Plate

1. Remove the throat plate **17** by turning the locking screw **30** with a screw driver 90° anti-clockwise.
2. Pull throat plate up and forward to expose the inside of the saw. DO NOT operate the saw without the throat plate.

Fitting the Rip Fence (Fig. F)

The rip fence can be installed in two positions on the right (Position 1 for 0 mm to 510 mm ripping, and Position 2 for 100 mm to 610 mm ripping,) and one position on the left of your table saw.

1. Unlock the rip fence latches **19**.
2. Holding the fence at an angle, align the locator pins (front and back) **31** on the fence rails with the fence head slots **32**.
3. Slide the head slots onto the pins and rotate the fence down until it rests on the rails.
4. Lock the fence in place by closing the front and back latches **19** onto the rails.

Fixing to Workbench (Fig. A)

- The machine frame between the feet on each side is provided with two holes **9** which allow fixing on a workbench. Use the holes diagonally.
- To improve the handling fix the machine on a piece of plywood of min 15 mm thick.

When in use the plywood sheet can be clamped to the workbench. This allows easier transportation of the machine, by releasing the clamps.

ADJUSTMENTS

Blade Adjustment

Blade Alignment (Parallel to Mitre Slot) (Fig. G)

WARNING: Cut Hazard. Check the blade at 0° and 45° to make sure blade does not hit the throat plate, causing personal injury.

If the blade appears to be out of alignment with the mitre slot on the table top, it will require calibration for alignment. To realign the blade and mitre slot, use the following procedure:

WARNING: To reduce the risk of injury, turn unit off and disconnect machine from power source before installing and removing accessories, before adjusting or changing set-ups or when making repairs. An accidental start-up can cause injury.

1. Using a 5 mm hex wrench, loosen rear pivot bracket fasteners **33**, located on the underside of the table, just enough to allow the bracket to move side-to-side.
2. Adjust the bracket until the blade is parallel to the mitre gauge slot.
3. Tighten the rear pivot bracket fasteners to 110–120 in-lbs (12.5–13.6 Nm).

Blade Height Adjustment (Fig. A)

The blade can be raised and lowered by turning the blade height adjustment wheel **6**.

Make sure the top three teeth of the blade are just breaking through the upper surface of the workpiece when sawing. This will ensure that the maximum number of teeth are removing material at any given time, thus giving optimum performance.

Aligning Guard Assembly to Blade (Fig. H)

1. Remove the throat plate. Refer to **Removing Throat Plate** under **Assembly and Adjustments**.
2. Raise the blade to full depth of cut and 0° bevel angle.
3. Locate the three small set screws **33**. These screws will be used to adjust the riving knife position.
4. Lay a straight edge on the table against two blade tips. The riving knife should not touch the straight edge.
5. If adjustment is needed, loosen the two larger lock screws **35**.

- Use the small set screws **33** to adjust the riving knife position. Lay the straight edge on the opposite side of the blade and repeat adjustments as needed.
- Lightly tighten the two larger lock screws **35**.
- Place a square flat against the riving knife to verify the riving knife is vertical and in-line with the blade.
- If needed, use the set screws to bring the riving knife vertical with the square.
- Repeat step 4 to verify position of riving knife. Repeat 5 thru 9 if necessary.
- Fully tighten the two larger lock screws **35**.

Parallel Adjustment (Fig. A, I, J)

For optimum performance, the blade must be parallel to the rip fence. This adjustment has been made at the factory. To re-adjust:

Position 1 Fence Alignment

- Install the fence in position 1 and unlock the rail lock lever **5**. Locate both locator pins **31** that support the fence on the front and rear rails.
- Loosen the rear locator pin screw and adjust the alignment of the fence in the groove until the fence face is parallel to the blade. Make sure you measure from the fence face to the front and back of the blade to ensure alignment.
- Tighten the locator screw and repeat on the left side of the blade.
- Check rip scale pointer adjustment (Fig. J).

Position 2 Fence Alignment (Fig. I)

- To align position 2 fence locator pins **31**, ensure position 1 pins have been aligned, refer to **Position 1 Fence Alignment**.
- Loosen the position 2 pins, then using the holes on the blade wrench **21** as a guide for positioning, align the pins (Fig. I).
- Tighten the locator pins (front and rear).

Adjusting the Rip Scale (Fig. J)

- Unlock the rail lock lever **5**.
- Set the blade at 0° bevel and move the fence in until it touches the blade.
- Lock the rail lock lever.
- Loosen the rip scale indicator screws **36** and set the rip scale indicator to read zero (0). Retighten the rip scale indicator screws. The yellow rip scale (top) reads correctly only when the fence is mounted on the right side of the blade and is in position 1 (for 0 mm to 510 mm ripping) not the 610 mm rip position. The white scale (bottom) reads correctly only when the fence is mounted on the right side of the blade and in position 2 (for position 100 mm to 610 mm ripping).

The rip scale reads correctly only when the fence is mounted to the right of the blade.

Rail Lock Adjustment (Fig. J, K)

The rail lock has been factory-set. If you need to re-adjust, proceed as follows:

- Lock the rail lock lever **5**.
- On the underside of the saw, loosen the jam nut **37**.
- Tighten the hex rod **38** until the spring on the locking system is compressed creating the desired tension on the rail lock lever. Retighten the jam nut against the hex rod.
- Flip the saw over and check that the fence does not move when the lock lever is engaged. If the fence is still loose, tighten the spring further.

Bevel Stop And Pointer Adjustment (Fig. L)

- Raise the blade fully by rotating the blade height adjustment wheel **6** clockwise until it stops.
- Unlock the bevel lock lever **7** by pushing it up and to the right. Loosen the bevel stop screw **39**.
- Place a square flat against the table top and against the blade between teeth. Ensure the bevel lock lever is in its unlocked, or up, position.
- Using the bevel lock lever, adjust the bevel angle until it is flat against the square.
- Tighten the bevel lock lever by pushing it down.
- Turn the bevel stop screw **39** to rotate the cam until it firmly contacts the bearing block. Tighten the bevel stop screw.
- Check the bevel angle scale. If the pointer does not read 0°, loosen pointer screw **40** and move the pointer so it reads correctly. Retighten the pointer screw.
- Repeat at 45°, but do not adjust pointer.

Mitre Gauge Adjustment (Fig. A)

To adjust mitre gauge **10** loosen knob, set to desired angle and tighten knob.

Body and Hand Position

Proper positioning of your body and hands when operating the table saw will make cutting easier, more accurate and safer.



WARNING:

- Never place your hands near the cutting area.
- Place your hands no closer than 150 mm from the blade.
- Do not cross your hands.
- Keep both feet firmly on the floor and maintain proper balance.

Prior to Operation



WARNING:

- Install the appropriate saw blade. Do not use excessively worn blades. The maximum rotation speed of the tool must not exceed that of the saw blade.
- Do not attempt to cut excessively small pieces.
- Allow the blade to cut freely. Do not force.
- Allow the motor to reach full speed before cutting.

OPERATION

Instructions for Use



WARNING: Always observe the safety instructions and applicable regulations.



WARNING: To reduce the risk of serious personal injury, turn tool off and disconnect battery pack before making any adjustments or removing/ installing attachments or accessories. An accidental start-up can cause injury.

The attention of UK users is drawn to the "woodworking machines regulations 1974" and any subsequent amendments.

Ensure the machine is placed to satisfy your ergonomic conditions in terms of table height and stability. The machine site shall be chosen so that the operator has a good overview and enough free surrounding space around the machine that allows handling of the workpiece without any restrictions.

To reduce effects of increased vibration, make sure the environment is not too cold, the machine and accessory are well maintained and the workpiece size is suitable for this machine.



WARNING:

- Always observe the safety instructions and applicable regulations.
- Ensure the machine is placed to satisfy ergonomic conditions in terms of table height and stability. The machine site shall be chosen so that the operator has a good overview and enough free surrounding space around the machine that allow handling of the workpiece without any restrictions.
- Install the appropriate saw blade. Do not use excessively worn blades. The maximum rotation speed of the tool must not exceed that of the saw blade.
- Do not attempt to cut excessively small pieces.
- Allow the blade to cut freely. Do not force.
- Allow the motor to reach full speed before cutting.
- Make sure all locking knobs and clamp handles are tight.
- Never place either hand in the blade area when the saw is connected to the electrical power source.
- Never use your saw for freehand cuts!
- Do not saw warped, bowed or cupped workpieces. There must be at least one straight, smooth side to go against the rip fence or mitre fence.
- Always support long workpieces to prevent kickback.
- Do not remove any cut-offs from the blade area while the blade is running.

Switching On and Off (Fig. A, M)

The on/off switch **8** (Fig. A) of your table saw offers multiple advantages:

- No-volt release function: should the power be shut off for any reason, the switch has to be deliberately reactivated.

- Lift the red paddle **41** and push green button **42** in to turn this saw on.
- Push the red button **43** or push down the red paddle to turn this saw off.

Rip Fence Operation (Fig. A, N)

Rail Lock Lever

The rail lock lever **5** locks the fence in place preventing movement during cutting. To lock the rail lever, push it down and toward the rear of the saw. To unlock, pull it up and toward the front of the saw.

NOTE: When ripping, always lock the rail lock lever.

Work Support Extension /Narrow Ripping Fence

Your table saw is equipped with a work support extension to support work that extends beyond the saw table.

To use the narrow ripping fence in the work support position, rotate it from its stored position as shown in Figure N, and slide the pins into the lower sets of slots **44** on both ends of the fence.

To use the narrow ripping fence in the narrow ripping position, snap the pins into the upper sets of slots **45** on both ends of the fence. This feature will allow 51 mm of extra clearance to the blade. Refer to Figure N.

NOTE: Retract the work support extension or adjust to narrow rip fence position whenever working over the table.

Fine Adjustment Knob

The fine adjustment knob **4** allows smaller adjustments when setting the fence. Before adjusting, be sure the rail lock lever is in its up or unlocked, position.

Rip Scale Pointer

The rip scale pointer will need to be adjusted for proper performance of the rip fence if the user switches between thick and thin kerf blades. The rip scale pointer only reads correctly for position 1 (0 mm to 510 mm), however for position 1 with narrow rip fence in use add 52 mm. See **Adjusting the Rip Scale** under **Assembly**.

Basic Saw Cuts

Ripping (Fig. A, B, O)



WARNING: Sharp edges.

1. Set the blade to 0°.
2. Lock the rip fence latch **19** (Fig. A).
3. Raise the blade until it is about 3 mm higher than the top of the workpiece.
4. Adjust the position of the fence, refer to **Rip Fence Operation**.
5. Hold the workpiece flat on the table and against the fence. Keep the workpiece away from the blade.
6. Keep both hands away from the path of the blade (Fig. O).

- Switch the machine on and allow the blade to reach full speed.
- Slowly feed the workpiece underneath the guard, keeping it firmly pressed against the rip fence. Allow the teeth to cut, and do not force the workpiece through the blade. The blade speed should be kept constant.
- Always use a push stick **22** when working close to the blade (Fig. O).
- After completing the cut, switch the machine off, allow the blade to stop and remove the workpiece.

**WARNING:**

- Never push or hold the "free" or cut-off-side of the workpiece.
- Do not cut excessively small workpieces.
- Always use a push stick when ripping small workpieces.

Bevel Cuts (Fig. A)

WARNING: Avoid bevel ripping on the beveling (left) side of the blade.

- Set the required bevel angle, by rotating lever **7** by pushing it up and to the right.
- Set to desired angle, rotate lever by pushing down and to the left to lock in place.
- Proceed as for ripping.

Cross-Cutting and Bevel Crosscutting

- Remove the rip fence and install the mitre gauge in the slot.
- Lock the mitre gauge at 0°.
- Proceed as for ripping.

Mitre Cuts (Fig. A)

- Set the mitre gauge **10** to the required angle.

NOTE: Always hold the workpiece tightly against the face of the mitre gauge.

- Proceed as for ripping.

Compound Mitre

This cut is a combination of a mitre and a bevel cut. Set the bevel to the angle required and proceed as for a cross-cut mitre.

Support for Long Pieces

- Always support long pieces.
- Support long workpieces using any convenient means such as saw-horses or similar devices to keep the ends from dropping.

**Dust Extraction (Fig. A)**

The machine is provided with a dust exhaust port **15** at the rear of the machine suitable for use with dust extraction equipment featuring 57/65 mm nozzles. Supplied with the machine is a reducer port for use of dust extraction nozzles of 34–40 mm diameter.

The blade guard assembly also features a dust exhaust port for 35 mm nozzles and AirLock system.

- During all operations, connect a dust extraction device designed in accordance with the relevant regulations regarding dust emission.
- Ensure that the dust extraction hose in use is suitable for the application and material being cut. Ensure proper hose management.
- Be aware that man-made materials such as chipboard or MDF produce more dust particles during cutting than natural timber.

Storage (Fig. P)

- Attach push stick **22** to fence.
- Remove blade guard assembly **11**. Refer to **Installing/Removing the Blade Guard Assembly and Riving Knife**. Place blade guard assembly into holder as shown, then turn lock 1/4 turn to lock in place.
- Slide closed end of blade wrenches **21** into catch then secure in place with wing nut.
- Insert guide bar of mitre gauge **10** into pocket until it bottoms out.
- Non thru-sawing riving knife **23** slides in place on back side of guard storage clip.
- To store fence **18**, snap work support in stored position. Remove fence from rails. Reattach fence upside down on left side of saw. Pivot fence lock latches to secure.

Transporting (Fig. A)

- Always carry the machine using the carry handles **14**.



WARNING: Always transport the machine with the upper blade guard fitted.

MAINTENANCE

Your DEWALT power tool has been designed to operate over a long period of time with a minimum of maintenance. Continuous satisfactory operation depends upon proper tool care and regular cleaning.



WARNING: To reduce the risk of serious personal injury, turn tool off and disconnect battery pack before making any adjustments or removing/installing attachments or accessories. An accidental start-up can cause injury.

The charger and battery pack are not serviceable.

**Lubrication (Fig. Q)**

The motor and bearings require no additional lubrication. If raising and lowering the blade becomes difficult, clean and grease the height adjustment screws:

- Unplug the saw from power source.
- Turn the saw on its side.
- Clean and lubricate the height adjustment screw threads **46** on the underside of this saw as shown in figure Q. Use general purpose grease.



Cleaning (Fig. A, R)

WARNING: Blow dirt and dust out of the main housing with dry air as often as dirt is seen collecting in and around the air vents. Wear approved eye protection and approved dust mask when performing this procedure.

WARNING: Never use solvents or other harsh chemicals for cleaning the non-metallic parts of the tool. These chemicals may weaken the materials used in these parts. Use a cloth dampened only with water and mild soap. Never let any liquid get inside the tool; never immerse any part of the tool into a liquid.

WARNING: To reduce the risk of injury, regularly clean the table top.

WARNING: To reduce the risk of injury, regularly clean the dust collection system.

The blade guard assembly **11** and throat plate must be placed in position before operating the saw.

Before use, carefully inspect upper and lower blade guards as well as the dust extraction tube to determine that it will operate properly. Ensure that chips, dust or work piece particles cannot lead to blockage of one of the functions.

In case workpiece fragments are jammed between saw blade and guards, disconnect the machine from the power supply and follow the instructions given in section **Mounting the saw blade**. Remove the jammed parts and reassemble the saw blade.

Keep the ventilation slots clear and regularly clean the housing with a soft cloth.

Regularly clean the dust collection system:

1. Turn the saw on its side, so the bottom, open part of the unit is accessible.
2. Open the dust access door **47** shown in figure R loosening the two screws **48** and detaching the door. Clean out the excess dust, Then reattach the door securing it with the screws.

Optional Accessories

WARNING: Since accessories, other than those offered by DEWALT, have not been tested with this product, use of such accessories with this tool could be hazardous. To reduce the risk of injury, only DEWALT recommended accessories should be used with this product.

Replace blade guard when worn. Contact your local DEWALT service centre for details on a blade guard replacement.

SAW BLADES: ALWAYS USE 210 mm noise reduced saw blades with 30 mm arbour holes. Blade speed rating must be at least 6000 RPM. Never use a smaller diameter blade. It will not be guarded properly.

BLADE DESCRIPTIONS

Application	Diameter	Teeth
Construction Saw Blades (fast rip)		
General Purpose	210 mm	24
Fine Crosscuts	210 mm	40
Woodworking Saw Blades (provide smooth, clean cuts)		
Fine crosscuts	210 mm	60

Consult your dealer for further information on the appropriate accessories.

Protecting the Environment



Separate collection. Products and batteries marked with this symbol must not be disposed of with normal household waste.

Products and batteries contain materials that can be recovered or recycled reducing the demand for raw materials. Please recycle electrical products and batteries according to local provisions. Further information is available at www.2helpU.com.

Rechargeable Battery Pack

This long life battery pack must be recharged when it fails to produce sufficient power on jobs which were easily done before. At the end of its technical life, discard it with due care for our environment:

- Run the battery pack down completely, then remove it from the tool.
- Li-Ion cells are recyclable. Take them to your dealer or a local recycling station. The collected battery packs will be recycled or disposed of properly.

Belgique et Luxembourg België en Luxemburg	DeWALT - Belgium BVBA Egide Walschaertsstraat 16 2800 Mechelen	Tel: NL 32 15 47 37 63 Tel: FR 32 15 47 37 64 Fax: 32 15 47 37 99	www.dewalt.be enduser.BE@SBDinc.com
Danmark	DeWALT Roskildevej 22 2620 Albertslund	Tel: 70 20 15 10 Fax: 70 22 49 10	www.dewalt.dk kundeservice.dk@sbdinc.com
Deutschland	DeWALT Richard Klinger Str. 11 65510 Idstein	Tel: 06126-21-1 Fax: 06126-21-2770	www.dewalt.de infodwge@sbdinc.com
Ελλάδα	DeWALT (Ελλάδα) Α.Ε. ΕΔΡΑ-ΓΡΑΦΕΙΑ : Στραβόβουος 7 & Λ. Βουλιαγμένης, Πλυσίδα 166 74, Αθήνα SERVICE : Ημερος, Τόπος 2 (Χάν Αδάμ) – 193 00 Ασπρόπυργος	Τηλ: 00302108981616 Φαξ: 00302108983570	www.dewalt.gr Greece.Service@sbdinc.com
España	DeWALT Iberica, S.C.A. Parc de Negocios "Mas Blau" Edificio Muntadas, c/Bergadà, 1, Of. A6 08820 El Prat de Llobregat (Barcelona)	Tel: 934 797 400 Fax: 934 797 419	www.dewalt.es respuesta.postventa@sbdinc.com
France	DeWALT 5, allée des Hêtres BP 30084, 69579 Limonest Cedex	Tel: 04 72 20 39 20 Fax: 04 72 20 39 00	www.dewalt.fr scfr@sbdinc.com
Schweiz Suisse Svizzera	DeWALT In der Luberzen 42 8902 Urdorf	Tel: 044 - 705 60 70 Fax: 044 - 700 70 67	www.dewalt.ch service@rofoag.ch
Ireland	DeWALT Calpe House Rock Hill Black Rock, Co. Dublin	Tel: 00353-2781800 Fax: 00353-2781811	www.dewalt.ie
Italia	DeWALT via EnergyPark 20871 Vimercate (MB), IT	Tel: 800-014333 39 030 2160200 Fax: 39 039 9510303	www.dewalt.it
Nederlands	DeWALT Netherlands BV Holtum Noordweg 35 6121 RE BORN, Postbus 83, 6120 AB BORN	Tel: 31 164 283 063 31 164 283 200	www.dewalt.nl
Norge	DeWALT Postboks 4613, Nydalen 0405 Oslo	Tel: 45 25 13 00 Fax: 45 25 08 00	www.dewalt.no kundeservice.no@sbdinc.com
Österreich	DeWALT Werkzeug Vertriebsges m.b.H Oberlaaerstrasse 248, A-1230 Wien	Tel: 01 - 66116 - 0 Fax: 01 - 66116 - 614	www.dewalt.at service.austria@sbdinc.com
Portugal	DeWALT Limited, SARL Centro de Escritórios de Sintra, Avenida Almirante Gago Coutinho, 32/134, Edifício 14 2710-418 Sintra	Tel: 214 66 75 00 Fax: 214 66 75 80	www.dewalt.pt resposta.posvenda@sbdinc.com
Suomi	DeWALT PL 4 01652T Helsinki	Puh: 010 400 4333 Faksi: 0800 411 340	www.dewalt.fi asiakaspalvelu.fi@sbdinc.com
Sverige	DeWALT Box 94 431 22 Mölndal	Tel: 031 68 61 60 Fax: 031 68 60 08	www.dewalt.se kundservice.se@sbdinc.com
Türkiye	KALE Hirdavat ve Makina A.Ş. Defterdar Mahallesi, Cad. No:15 Edimekapı / Etiler / İSTANBUL 34050 TÜRKİYE	Tel: 0212 533 52 55 Faks: 0212 533 10 05	www.dewalt.com.tr
United Kingdom	DeWALT, 210 Bath Road; Slough, Berks SL1 3YD	Tel: 01753-567055 Fax: 01753-572112	www.dewalt.co.uk emeaservice@sbdinc.com
Australia	DeWALT 810 Whitehorse Road Box Hill VIC 3103 Australia	Tel: Aust 1800 338 002 Tel: NZ 0800 339 258	www.dewalt.com.au www.dewalt.co.nz
Middle East Africa	DeWALT P.O. Box - 17164, Jebel Ali Free Zone (South), Dubai, UAE	Tel: 971 4 812 7400 Fax: 971 4 2822765	www.dewalt.ae Service.MEA@sbdinc.com