

# **HIKOKI**

## **Impact Drill Model DV 16V**

### **Handling instructions**

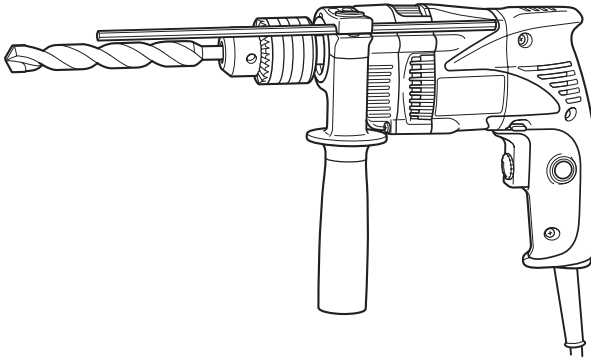

**Note:**

Before using this Electric Power Tool, carefully read through these HANDLING INSTRUCTIONS to ensure efficient, safe operation. It is recommended that these INSTRUCTIONS be kept readily available as an important reference when using this power tool.



---

## GENERAL POWER TOOL SAFETY WARNINGS

---

### WARNING

Read all safety warnings and all instructions.

Failure to follow the warnings and instructions may result in electric shock, fire and/or serious injury.

Save all warnings and instructions for future reference.

The term "power tool" in the warnings refers to your mains-operated (corded) power tool or battery-operated (cordless) power tool.

#### 1) Work area safety

- a) **Keep work area clean and well lit.**  
*Cluttered or dark areas invite accidents.*
- b) **Do not operate power tools in explosive atmospheres, such as in the presence of flammable liquids, gases or dust.**  
*Power tools create sparks which may ignite the dust or fumes.*
- c) **Keep children and bystanders away while operating a power tool.**  
*Distractions can cause you to lose control.*

#### 2) Electrical safety

- a) **Power tool plugs must match the outlet. Never modify the plug in any way. Do not use any adapter plugs with earthed (grounded) power tools.**  
*Unmodified plugs and matching outlets will reduce risk of electric shock.*
- b) **Avoid body contact with earthed or grounded surfaces, such as pipes, radiators, ranges and refrigerators.**  
*There is an increased risk of electric shock if your body is earthed or grounded.*
- c) **Do not expose power tools to rain or wet conditions.**  
*Water entering a power tool will increase the risk of electric shock.*
- d) **Do not abuse the cord. Never use the cord for carrying, pulling or unplugging the power tool. Keep cord away from heat, oil, sharp edges or moving parts.**  
*Damaged or entangled cords increase the risk of electric shock.*
- e) **When operating a power tool outdoors, use an extension cord suitable for outdoor use.**  
*Use of a cord suitable for outdoor use reduces the risk of electric shock.*
- f) **If operating a power tool in a damp location is unavoidable, use a residual current device (RCD) protected supply.**  
*Use of an RCD reduces the risk of electric shock.*

#### 3) Personal safety

- a) **Stay alert, watch what you are doing and use common sense when operating a power tool. Do not use a power tool while you are tired or under the influence of drugs, alcohol or medication.**  
*A moment of inattention while operating power tools may result in serious personal injury.*
- b) **Use personal protective equipment. Always wear eye protection.**  
*Protective equipment such as dust mask, non-skid safety shoes, hard hat, or hearing protection used for appropriate conditions will reduce personal injuries.*
- c) **Prevent unintentional starting. Ensure the switch is in the off-position before connecting to power source and/or battery pack, picking up or carrying the tool.**

*Carrying power tools with your finger on the switch or energising power tools that have the switch on invites accidents.*

- d) **Remove any adjusting key or wrench before turning the power tool on.**  
*A wrench or a key left attached to a rotating part of the power tool may result in personal injury.*
- e) **Do not overreach. Keep proper footing and balance at all times.**  
*This enables better control of the power tool in unexpected situations.*
- f) **Dress properly. Do not wear loose clothing or jewellery. Keep your hair, clothing and gloves away from moving parts.**  
*Loose clothes, jewellery or long hair can be caught in moving parts.*
- g) **If devices are provided for the connection of dust extraction and collection facilities, ensure these are connected and properly used.**  
*Use of dust collection can reduce dust related hazards.*

#### 4) Power tool use and care

- a) **Do not force the power tool. Use the correct power tool for your application.**  
*The correct power tool will do the job better and safer at the rate for which it was designed.*
- b) **Do not use the power tool if the switch does not turn it on and off.**  
*Any power tool that cannot be controlled with the switch is dangerous and must be repaired.*
- c) **Disconnect the plug from the power source and/or the battery pack from the power tool before making any adjustments, changing accessories, or storing power tools.**  
*Such preventive safety measures reduce the risk of starting the power tool accidentally.*
- d) **Store idle power tools out of the reach of children and do not allow persons unfamiliar with the power tool or these instructions to operate the power tool. Power tools are dangerous in the hands of untrained users.**
- e) **Maintain power tools. Check for misalignment or binding of moving parts, breakage of parts and any other condition that may affect the power tool's operation.**  
**If damaged, have the power tool repaired before use.**  
*Many accidents are caused by poorly maintained power tools.*
- f) **Keep cutting tools sharp and clean.**  
*Properly maintained cutting tools with sharp cutting edges are less likely to bind and are easier to control.*
- g) **Use the power tool, accessories and tool bits etc. in accordance with these instructions, taking into account the working conditions and the work to be performed.**  
*Use of the power tool for operations different from those intended could result in a hazardous situation.*

#### 5) Service

- a) **Have your power tool serviced by a qualified repair person using only identical replacement parts.**  
*This will ensure that the safety of the power tool is maintained.*

### PRECAUTION

Keep children and infirm persons away.

When not in use, tools should be stored out of reach of children and infirm persons.

## IMPACT DRILL SAFETY WARNINGS

1. **Wear ear protectors with impact drills.**  
Exposure to noise can cause hearing loss.
2. **Use auxiliary handles supplied with the tool.**  
Loss of control can cause personal injury.
3. **Hold power tool by insulated gripping surfaces, when performing an operation where the cutting accessory may contact hidden wiring or its own cord.** Cutting accessory contacting a "live" wire may make exposed metal parts of the power tool "live" and could give the operator an electric shock.
4. Before drilling into walls, ceilings or floors, ensure that there are no concealed power cables inside.
5. When boring concrete or similar hard materials in IMPACT mode, push the R-side of the push button. (Fig. 1)

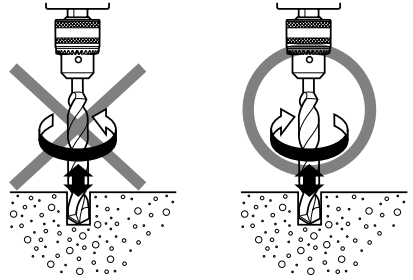

Fig. 1

## SPECIFICATIONS

Voltage (by areas)*	(110 V, 220 V, 230 V, 240 V) ~	
Power input	590 W*	
No load speed	0–2900 min <sup>-1</sup>	
Drill chuck capacity	13 mm	
Capacity	Steel	13 mm
	Concrete	16 mm
	Wood	25 mm
Full load impact rate	34500 min <sup>-1</sup>	
Weight (without cord)	1.5 kg	

\*Be sure to check the nameplate on product as it is subject to change by areas.

## STANDARD ACCESSORIES

- |  |   |
|--|---|
| (1) Chuck Wrench (Spec. only for chuck fitted with chuck wrench) ..... | 1 |
| (2) Side Handle .....  | 1 |
| (3) Depth Gauge .....  | 1 |
| (4) Plastic case .....   | 1 |
- Standard accessories are subject to change without notice.

## OPTIONAL ACCESSORIES (sold separately)

- |  |
|--|
| (1) Impact Drill Bit (for concrete)<br>3.2 mm – 20 mm dia. |
| (2) Hook (A)   |
- Optional accessories are subject to change without notice.

## APPLICATIONS

- By combined actions of ROTATION and IMPACT:  
Boring holes in hard materials (concrete, marble, granite, tiles, etc.)
- By ROTATIONAL action:  
Boring holes in metal, wood and plastic.

## PRIOR TO OPERATION

1. **Power source**  
Ensure that the power source to be utilized conforms to the power requirements specified on the product nameplate.

2. **Power switch**

Ensure that the power switch is in the OFF position. If the plug is connected to a receptacle while the power switch is in the ON position, the power tool will start operating immediately, inviting serious accident.

3. **Extension cord**

When the work area is removed from the power source. Use an extension cord of sufficient thickness and rated capacity. The extension cord should be kept as short as practicable.

4. **Selecting the appropriate drill bit**

- When boring concrete or stone  
Use the drill bits specified in the Optional Accessories.
- When boring metal or plastic  
Use an ordinary metalworking drill bit.
- When boring wood  
Use an ordinary woodworking drill bit.  
However, when drilling 6.5 mm or smaller holes, use a metalworking drill bit.

5. **Mounting and dismounting of the bit.**

### For Drill chuck with chuck wrench (Fig. 2)

- (1) Open the chuck jaws, and insert the bit into the chuck.
- (2) Place the chuck wrench in each of the three holes in the chuck, and turn it in the clockwise direction (viewed from the front side). Tighten securely.
- (3) To remove the bit, place the chuck wrench into one of the holes in the chuck and turn it in the counterclockwise direction.

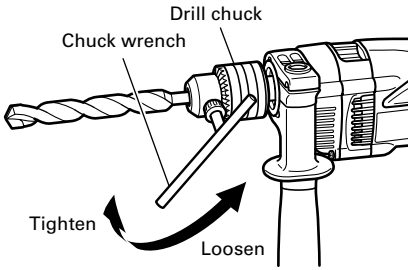

Fig. 2

**For keyless chuck (Fig. 3)**

- (1) Open the chuck jaws, and insert the bit into the chuck.  
To open the chuck jaws, hold the ring while turning the sleeve in the counterclockwise direction (viewed from the front side).
- (2) Firmly grasp the ring and turn the sleeve in the clockwise direction. Tighten securely.
- (3) To remove the bit, firmly grasp the ring and turn the sleeve in the counterclockwise direction.

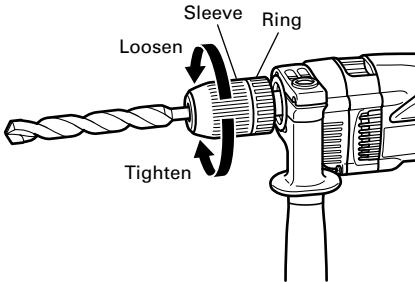

Fig. 3

- (4) When the sleeve does not become loose any further, fix the side handle to retaining ring, hold side handle firmly, then turn the sleeve to loosen by hand. (Fig. 4)

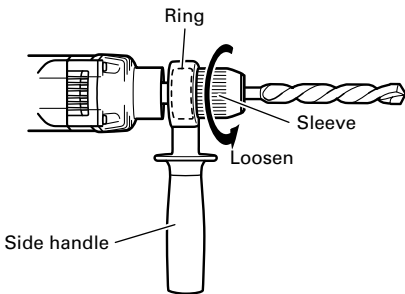

Fig. 4

**6. Check the rotational direction (Fig. 5)**

The bit rotates clockwise (viewed from the rear side) by pushing the R-side of the push button. The L-side of the push button is pushed to turn the bit counterclockwise.

(The (L) and (R) marks are provided on the body.)

**CAUTION**

Always use the impact drill with clockwise rotation, when using it as an impact drill.

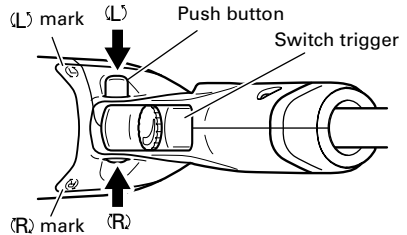

Fig. 5

**7. Fixing the side handle (Fig. 6)**

Attach the side handle to the mounting part. Rotate the side handle grip in a clockwise direction to secure it.

Set the side handle to a position that is suited to the operation and then securely tighten the side handle grip.

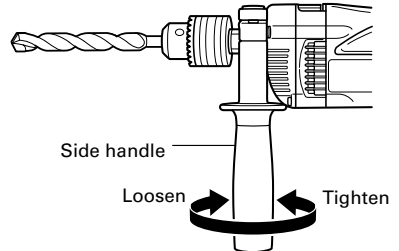

Fig. 6

To attach a depth gauge on the side handle, insert the gauge into the U-shaped groove on the side handle, adjust the position of the depth gauge in accordance with the desired depth of the hole, and firmly tighten the side handle grip. (Fig. 7)

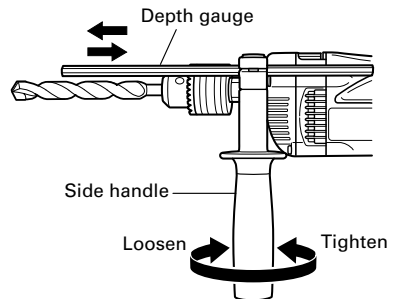

Fig. 7

## 8. IMPACT to ROTATION changeover (Fig. 8)

Shift the change lever between the right and left positions to switch easily between IMPACT (rotation and impact) and ROTATION (rotation only), respectively.

To bore holes in hard materials such as concrete, stone and tiles, shift the change lever to the right-hand position (as indicated by the **T** mark).

The drill bit operates by the combined actions of impact and rotation.

To bore holes in metal, wood and plastic, shift the change lever to the left-hand position (as indicated by the **R** mark). The drill bit operates by rotational action only, as in the case of a conventional electric drill.

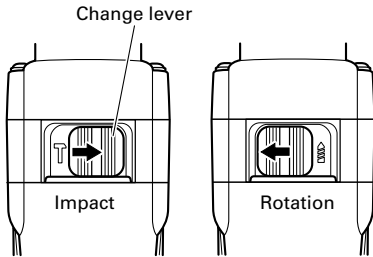

Fig. 8

### CAUTION

- Do not use the Impact Drill in the IMPACT function if the material can be bored by rotation only. Such action will not only reduce drill efficiency, but may also damage the drill tip.
- Operating the Impact Drill with the change lever in mid-position may result in damage. When switching, make sure that you shift the change lever to the correct position.

## 9. Attaching the hook. (Optional accessory) (Fig. 9)

To attach the hook (A), it is necessary to disassemble the handle portion which covered the tool's electrical system. For your continued safety and electrical shock protection, installing the hook (A) on this drill should ONLY be performed by a HIKOKI AUTHORIZED SERVICE CENTER.

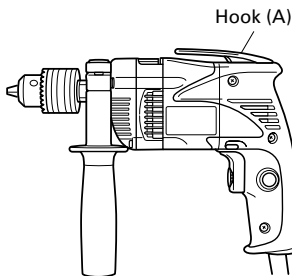

Fig. 9

## 10. RCD

The use of a residual current device with a rated residual current of 30mA or less at all times is recommended.

### CAUTION

When the power tool is used with a hook fixed to it, pay attention to the following points:

- Before hanging the main unit from the waist belt, make sure that the drill has come to a complete stop. While it is suspended from the waist belt, the power plug must be disconnected from the power source.
- Do not walk about with the power tool hanging from the waist belt.
- In the case of operation in a high place, it is dangerous to drop the tool accidentally. If the hook is deformed or hung from the wrong position, there is danger that the hook will slip off and the tool will fall. Be careful to avoid danger.
- In making a through hole, the power tool sometimes shakes violently when the workpiece is pierced, for example. Be careful you are not hurt by the hook even if such situation happens.

### HOW TO USE

#### 1. Switch operation

- When the trigger is depressed, the tool rotates. When the trigger is released, the tool stops.
- The rotational speed of the drill can be controlled by varying the amount that the trigger switch is pulled. Speed is low when the trigger switch is pulled slightly and increases as the trigger switch is pulled more.
- The desired rotation speed can be pre-selected with the speed control dial. Turn the speed control dial clockwise for higher speed and counterclockwise for lower speed. (Fig. 10)
- Pulling the trigger and pushing the stopper, it keeps the switched-on condition which is convenient for continuous running. When switching off, the stopper can be disconnected by pulling the trigger again.

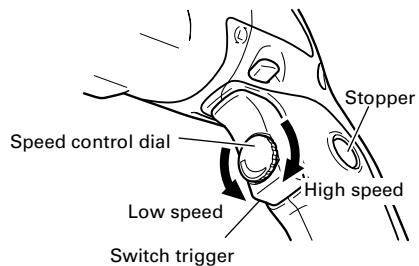

Fig. 10

#### 2. When using as a Drill or an Impact Drill

##### (1) Pressing force of the drill

You cannot drill holes more quickly even if you press the drill with a stronger force than necessary. It not only damages tip of drill bit and decreases the efficiency of operation, but also shortens the life of the drill tip.

##### (2) In case of penetrating holes

Drill bits can be broken when the material being drilled is penetrated. It is important to decrease pressing force just before penetrating.

### CAUTION

In continuous operation, conduct no-load operation for five seconds after completing a drilling job.

- (3) When a thick drill bit is used  
Your arm is subjected to larger reaction force when a thicker drill bit is used. Be careful not to be moved by the reaction force. For this, establish a foothold, hold the unit tightly with both hands perpendicularly to the material being drilled.

---

## **MAINTENANCE AND INSPECTION**

---

### **1. Inspecting the drill bits**

Since use of an abraded drill bits will cause motor malfunctioning and degraded efficiency, replace the drill bits with a new one or resharpening without delay when abrasion is noted.

### **2. Inspecting the mounting screws**

Regularly inspect all mounting screws and ensure that they are properly tightened. Should any of the screws be loose, retighten them immediately. Failure to do so could result in serious hazard.

### **3. Maintenance of the motor**

The motor unit winding is the very “heart” of the power tool. Exercise due care to ensure the winding does not become damaged and/or wet with oil or water.

### **4. Inspecting the carbon brushes**

For your continued safety and electrical shock protection, carbon brush inspection and replacement on this tool should ONLY be performed by a HiKOKI AUTHORIZED SERVICE CENTER.

### **5. Replacing supply cord**

If the supply cord of Tool is damaged, the Tool must be returned to a HiKOKI Authorized Service Center for the cord to be replaced.

### **6. Service parts list**

- A: Item No.
- B: Code No.
- C: No. Used
- D: Remarks

### **CAUTION**

Repair, modification and inspection of HiKOKI Power Tools must be carried out by a HiKOKI Authorized Service Center.

This Parts List will be helpful if presented with the tool to the HiKOKI Authorized Service Center when requesting repair or other maintenance.

In the operation and maintenance of power tools, the safety regulations and standards prescribed in each country must be observed.

### **MODIFICATION**

HiKOKI Power Tools are constantly being improved and modified to incorporate the latest technological advancements.

Accordingly, some parts (i.e. code numbers and/or design) may be changed without prior notice.

---

### **NOTE**

Due to HiKOKI's continuing program of research and development, the specifications herein are subject to change without prior notice.

---

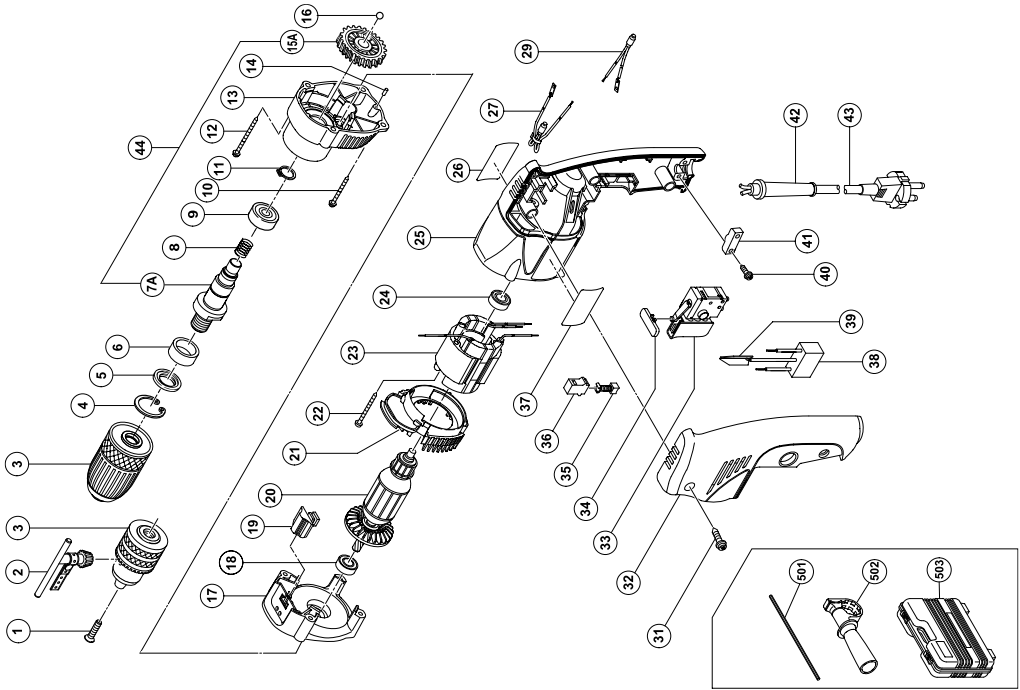

A	B	C	D
1	995-344	1	M6 x 25
2	987-576	1	13VLRH-N
3-1	322-357	1	13VLRB-D
3-2	321-814	1	
4	948-001	1	
5	971-654	1	
6	322-515	1	
7A	322-513	1	
8	322-514	1	
9	600-2VV	1	6002VVCMP2S2L
10	306-664	2	D4 x 40
11	939-544	1	
12	322-516	2	D4 x 55
13	322-512	1	
14	322-511	1	
15A	323-527	1	
16	959-150	1	D6.35
17	322-509	1	
18	608-DDM	1	608DDC2PS2L
19	322-510	1	
20-1	360-626C	1	110V
20-2	360-626E	1	220V-240V
21	322-508	1	
22	950-515	2	D4 x 50
23-1	350-573C	1	110V
23-2	340-573E	1	220V-230V
23-3	340-573F	1	240V
24	608-VVM	1	608VVC2PS2L
25	321-622	1	
26		1	
27-1	322-517	1	220V-240V
27-2	322-518	1	"GBR(110V)"
29-1	321-634	1	110V-240V
29-2	322-519	1	"GBR(110V)"
31	301-653	3	D4 x 20
32	321-629	1	
33	321-632	1	
34	321-628	1	
35	999-041	2	
36	955-203	2	
37		1	
38	994-273	1	
39	992-635	1	
40	984-750	2	D4 x 16
41	937-631	1	
42	953-327	1	D8.8
43		1	
44		1	"7A, 15A"
501		1	
502		1	
503		1	

# **Koki Holdings Co., Ltd.**

Shinagawa Intercity Tower A, 15-1, Konan 2-chome,  
Minato-ku, Tokyo, Japan

806

Code No. C99126212 F  
Printed in China