DEWALT®

www.DEWALT.com

DW349

Figure 1

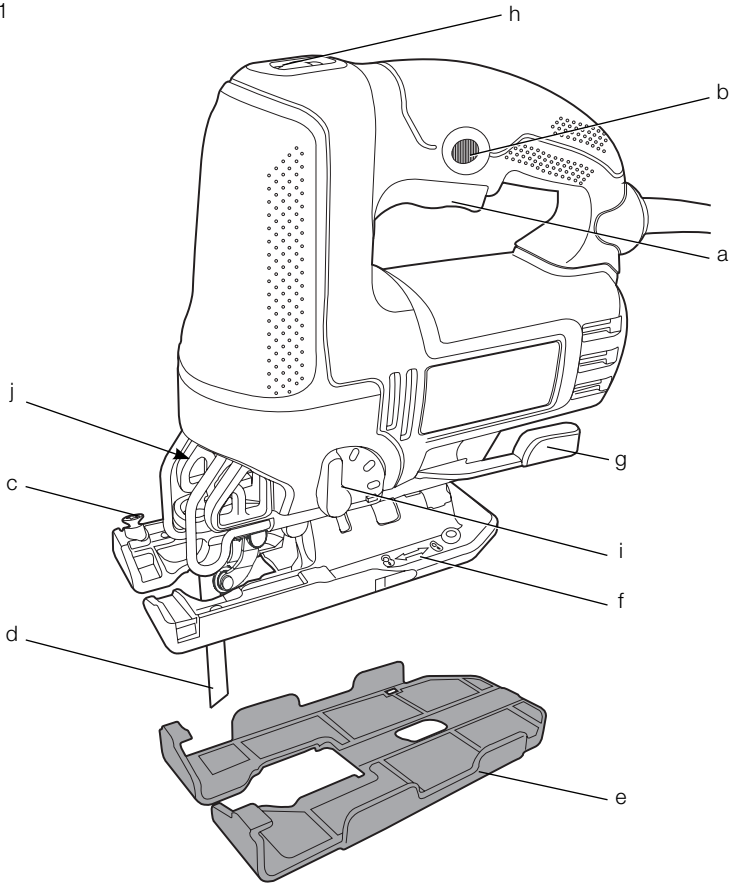

Figure 2

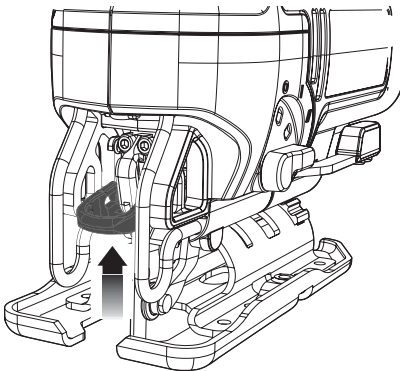

Figure 3

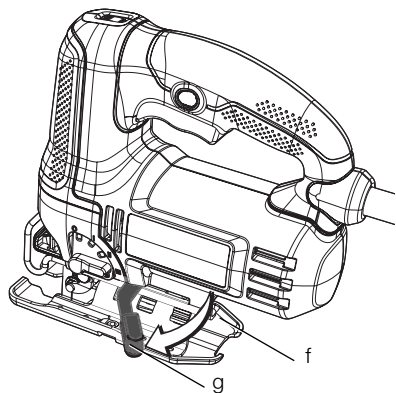

Figure 4

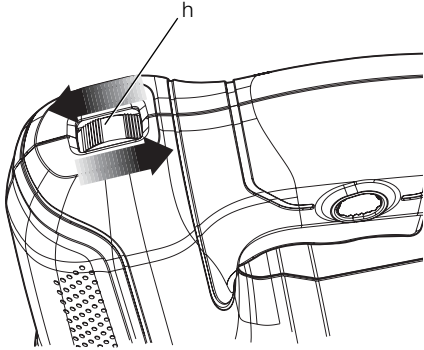

Figure 5

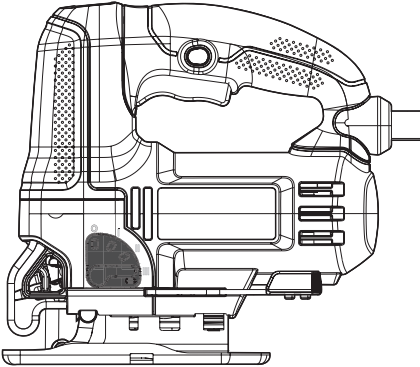

Figure 6

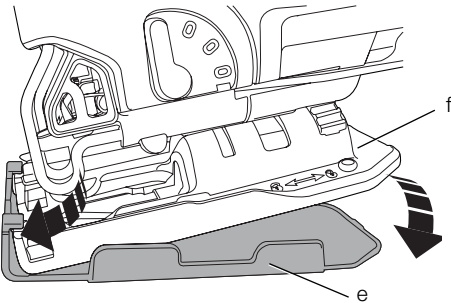

Figure 7

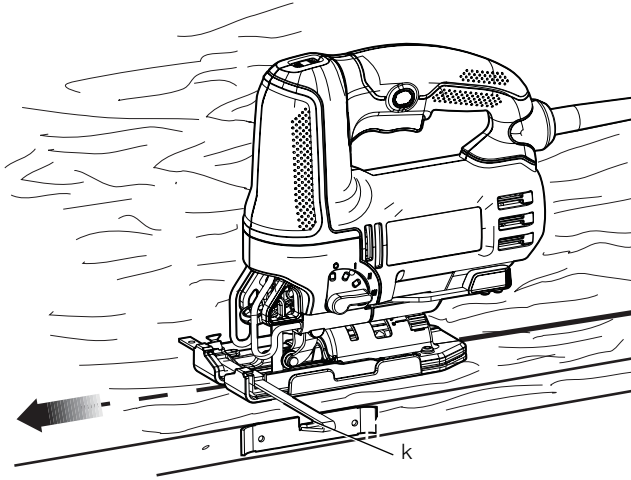
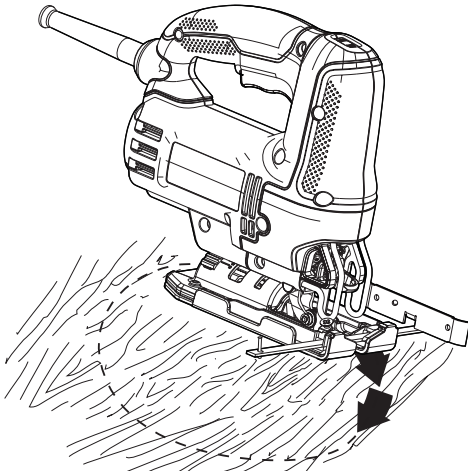

Figure 8



JIG SAW

DW349

Congratulations!

You have chosen a DEWALT tool. Years of experience, thorough product development and innovation make DEWALT one of the most reliable partners for professional power tool users.

Technical Data

		DW349-IN
Voltage	V	220-240
Power input	W	500
Frequency	Hz	50
No-load speed	/min	800-3200
Stroke length	mm	20
Weight	kg	2.7

Definitions: Safety Guidelines

The definitions below describe the level of severity for each signal word. Please read the manual and pay attention to these symbols.



DANGER: Indicates an imminently hazardous situation which, if not avoided, **will result in death or serious injury.**



WARNING: Indicates a potentially hazardous situation which, if not avoided, **could result in death or serious injury.**



CAUTION: Indicates a potentially hazardous situation which, if not avoided, **may result in minor or moderate injury.**

NOTICE: Indicates a practice **not related to personal injury** which, if not avoided, **may result in property damage.**



Denotes risk of electric shock.



Denotes risk of fire.



WARNING: To reduce the risk of injury, read the instruction manual.

General Power Tool Safety Warnings



WARNING Read all safety warnings and instructions. Failure to follow the warnings and instructions may result in electric shock, fire and/or serious injury.

SAVE ALL WARNINGS AND INSTRUCTIONS FOR FUTURE REFERENCE

The term "power tool" in the warnings refers to your mains-operated (corded) power tool or battery-operated (cordless) power tool.

1) WORK AREA SAFETY

- Keep work area clean and well lit.** Cluttered or dark areas invite accidents.
- Do not operate power tools in explosive atmospheres, such as in the presence of flammable liquids, gases or dust.** Power tools create sparks which may ignite the dust or fumes.
- Keep children and bystanders away while operating a power tool.** Distractions can cause you to lose control.

2) ELECTRICAL SAFETY

- Power tool plugs must match the outlet. Never modify the plug in any way. Do not use any adapter plugs with earthed (grounded) power tools.** Unmodified plugs and matching outlets will reduce risk of electric shock.
- Avoid body contact with earthed or grounded surfaces such as pipes, radiators, ranges and refrigerators.** There is an increased risk of electric shock if your body is earthed or grounded.
- Do not expose power tools to rain or wet conditions.** Water entering a power tool will increase the risk of electric shock.
- Do not abuse the cord. Never use the cord for carrying, pulling or unplugging the power tool. Keep cord away from heat, oil, sharp edges or moving parts.** Damaged or entangled cords increase the risk of electric shock.
- When operating a power tool outdoors, use an extension cord suitable for outdoor use.** Use of a cord suitable for outdoor use reduces the risk of electric shock.
- If operating a power tool in a damp location is unavoidable, use a residual**

current device (RCD) protected supply.
Use of an RCD reduces the risk of electric shock.

3) PERSONAL SAFETY

- a) **Stay alert, watch what you are doing and use common sense when operating a power tool. Do not use a power tool while you are tired or under the influence of drugs, alcohol or medication.** A moment of inattention while operating power tools may result in serious personal injury.
- b) **Use personal protective equipment. Always wear eye protection.** Protective equipment such as dust mask, non-skid safety shoes, hard hat, or hearing protection used for appropriate conditions will reduce personal injuries.
- c) **Prevent unintentional starting. Ensure the switch is in the off position before connecting to power source and/or battery pack, picking up or carrying the tool.** Carrying power tools with your finger on the switch or energising power tools that have the switch on invites accidents.
- d) **Remove any adjusting key or wrench before turning the power tool on.** A wrench or a key left attached to a rotating part of the power tool may result in personal injury.
- e) **Do not overreach. Keep proper footing and balance at all times.** This enables better control of the power tool in unexpected situations.
- f) **Dress properly. Do not wear loose clothing or jewellery. Keep your hair, clothing and gloves away from moving parts.** Loose clothes, jewellery or long hair can be caught in moving parts.
- g) **If devices are provided for the connection of dust extraction and collection facilities, ensure these are connected and properly used.** Use of dust collection can reduce dust-related hazards.

4) POWER TOOL USE AND CARE

- a) **Do not force the power tool. Use the correct power tool for your application.** The correct power tool will do the job better and safer at the rate for which it was designed.
- b) **Do not use the power tool if the switch does not turn it on and off.** Any power tool that cannot be controlled with the switch is dangerous and must be repaired.
- c) **Disconnect the plug from the power source and/or the battery pack from the power tool before making any**

adjustments, changing accessories, or storing power tools. Such preventive safety measures reduce the risk of starting the power tool accidentally.

- d) **Store idle power tools out of the reach of children and do not allow persons unfamiliar with the power tool or these instructions to operate the power tool.** Power tools are dangerous in the hands of untrained users.
- e) **Maintain power tools. Check for misalignment or binding of moving parts, breakage of parts and any other condition that may affect the power tool's operation. If damaged, have the power tool repaired before use.** Many accidents are caused by poorly maintained power tools.
- f) **Keep cutting tools sharp and clean.** Properly maintained cutting tools with sharp cutting edges are less likely to bind and are easier to control.
- g) **Use the power tool, accessories and tool bits etc., in accordance with these instructions taking into account the working conditions and the work to be performed.** Use of the power tool for operations different from those intended could result in a hazardous situation.

5) SERVICE

- a) **Have your power tool serviced by a qualified repair person using only identical replacement parts.** This will ensure that the safety of the power tool is maintained.

Additional Specific Safety Rules for Jig Saws

- **Hold power tools by insulated gripping surfaces, when performing an operation where the cutting accessory may contact hidden wiring or its own cord.** Cutting accessory contacting a "live" wire may make exposed metal parts of the power tool "live" and could give the operator an electric shock.
- **Use clamps or another practical way to secure and support the work piece to a stable platform.** Holding the work by hand or against your body leaves it unstable and may lead to loss of control.
- **Keep hands away from cutting area.** Never reach underneath the material for any reason. Hold front of saw by grasping the contoured gripping area. Do not insert fingers or thumb into the vicinity of the reciprocating blade and blade clamp. Do not stabilize the saw by

gripping the shoe.

- **Keep blades sharp.** Dull blades may cause the saw to swerve or stall under pressure.
- **When cutting pipe or conduit** ensure that they are free from water, electrical wiring, etc.
- **Allow the motor to come to a complete stop before withdrawing the blade from the kerf (the slot created by cutting).** A moving blade may impact the workpiece causing a broken blade, workpiece damage or loss of control and possible personal injury.
- **Do not touch the workpiece or the blade immediately after operating the tool.** They can become very hot.
- **Keep handles dry, clean, free from oil and grease.** This will enable better control of the tool.
- **Clean out your tool often, especially after heavy use.** Dust and grit containing metal particles often accumulate on interior surfaces and could create an electric shock hazard.
- **Do not operate this tool for long periods of time.** Vibration caused by the operating action of this tool may cause permanent injury to fingers, hands, and arms. Use gloves to provide extra cushion, take frequent rest periods, and limit daily time of use.
- **Avoid prolonged contact with dust from power sanding, sawing, grinding, drilling, and other construction activities. Wear protective clothing and wash exposed areas with soap and water.** Allowing dust to get into your mouth, eyes, or lay on the skin may promote absorption of harmful chemicals.

Markings on Tool

The following pictogram is shown on the tool:



Read instruction manual before use.

Symbols

The label on your tool may include the following symbols:

- V volts
- A amperes
- Hz hertz
- W watts
- min minutes
- ~ alternating current
- ==== direct current

n_0 no load speed

 Class I Construction

 earthing terminal (grounded)

 Class II Construction
(double insulated)

 safety alert symbol

.../min.... revolutions or reciprocation
per minutue

*s*rpm surface feet per minute

DATE CODE POSITION (FIG. 1)

The Date Code (n), which also includes the year of manufacture, is printed into the housing.

Example:

2013 XX XX

Year of Manufacture

Package Contents

The package contains:

- 1 Jig saw
- 1 Blade
- 1 Depth adjustment rod
- 1 Instruction manual
- 1 Warranty card
- 1 Service center list
- Check for damage to the tool, parts or accessories which may have occurred during transport.
- Take the time to thoroughly read and understand this manual prior to operation.

Description (fig. 1)



WARNING: Never modify the power tool or any part of it. Damage or personal injury could result.

- a. Trigger switch
- b. Lock-on button
- c. Saw blade locking lever
- d. Saw blade
- e. Shoe sleeve
- f. Shoe
- g. Shoe beveling lever
- h. Speed control wheel
- i. Cutting action lever
- j. LED Light

Electrical Safety



This tool is double insulated; therefore no earth wire is required. Always check that the power supply corresponds to the voltages on the rating plate

If the supply cord is damaged, it must be replaced by the manufacturer or an authorised DEWALT Service Centre in order to avoid a hazard.

INTENDED USE

This jig saw is designed for professional sawing applications.

DO NOT use under wet conditions or in presence of flammable liquids or gases.

This jig saw is a professional power tool.

DO NOT let children come into contact with the tool. Supervision is required when inexperienced operators use this tool.

- This tool is not intended for use by persons (including children) with reduced physical, sensory or mental capabilities, or lack of experience and knowledge, unless they have been given supervision or instruction concerning use of the appliance by a person responsible for their safety. Children should be supervised to ensure that they do not play with the appliance.

OPERATION



Warning: Before attempting any of the following operations, make sure that the tool is switched off and unplugged and that the saw blade has stopped. Used saw blades can be hot. The tool always is supplied via residual current device with a rated residual current 30mA or less.

Blade Installation (fig 2)

1. Push the saw blade locking lever (c) upward.
2. With teeth facing forward, insert the shank of the saw blade into the blade holder as far as it will go.
3. Release the lever.
4. Check to ensure blade is secure before cutting.

Adjusting the Shoe for Bevel Cuts (fig. 3)



WARNING: Never use the tool when the shoe is loose or removed. The shoe plate can be set to a left or right bevel angle of up to 45°.

TO SET THE BEVEL ANGLE

1. Pull the shoe beveling lever (g) out and away from the saw to unlock the shoe (f) as shown in Figure 3.
2. Slide the shoe forward to release it from the 0° positive stop position.
3. The shoe can be beveled to the left or to the right and has detents at 15°, 30° and 45°.
4. Set the shoe to the desired bevel angle. Use a protractor to verify angle accuracy.
5. Push the shoe beveling lever back towards the saw to lock the shoe.

TO RESET THE SHOE FOR STRAIGHT CUTS

1. Pull the shoe beveling lever (g) out and away from the saw to unlock the shoe (f) as shown in figure 3.
2. Rotate shoe to an angle of approximately 0° and then pull shoe backwards to engage the 0° positive stop.
3. Push the shoe beveling lever back towards the saw to lock the shoe.

Switching On and Off

1. To switch the tool on, squeeze the trigger switch (a).
2. For continuous operation, squeeze the trigger switch then depress the lock-on button (b). Once lock-on button is depressed, release the trigger switch.
3. To switch the tool off, release the trigger switch. To switch the tool off, when in continuous operation, squeeze the trigger and the lock will disengage.

Variable Speed Control (fig. 4)

A speed control wheel (h) is located on the top of the saw. The speed increases as the wheel is turned from a low speed setting of 1 to a high speed setting of 7.

Cutting Action – Orbital or Straight (fig. 5)



WARNING: Check that the tool is not locked **ON** before connecting it to a power supply. If the trigger switch is locked on when the tool is connected to the power supply, it will start immediately. Damage to your tool or personal injury may result. This jig saw is equipped with four cutting actions, three orbital and one straight. Orbital action

has a more aggressive blade motion and is designed for cutting in soft materials like wood or plastic. Orbital action provides a faster cut, but with a less smooth cut across the material. In orbital action, the blade moves forward during the cutting stroke in addition to the up and down motion.

NOTE: Metal or hardwoods should never be cut in orbital action.

TO ADJUST THE CUTTING ACTION

1. Move the cutting action lever (i) between the four cutting positions: 0, 1, 2, and 3.
2. Position 0 is straight cutting.
3. Positions 1, 2, and 3 are orbital cutting.

The aggressiveness of the cut increases as the lever is adjusted from one to three, with three being the most aggressive cut.

LED Light

The jig saw is equipped with a light which projects on the cutting path.

The light will come on when the trigger switch is depressed and will go off when the trigger switch is released.

Removable Shoe Sleeve (fig. 6)

The non-marring shoe sleeve (e) should be used when cutting surfaces that scratch easily, such as laminate, veneer, or paint. It can also be used to protect the shoe surface during transportation and storage.

To attach shoe sleeve, place the front of the shoe (f) into the front of the shoe sleeve (e) and lower the jig saw as shown in figure 6. The shoe sleeve will click securely onto the rear of the shoe.

To remove shoe sleeve, grasp the sleeve from the bottom at the two rear tabs and pull down and away from the shoe

Hints for Optimum Use

SAWING LAMINATES

As the saw blade cuts on the upward stroke, splintering may occur on the surface closest to the shoe plate.

- Use a fine-tooth saw blade.
- Saw from the back surface of the workpiece.
- To minimize splintering, clamp a piece of scrap wood or hardboard to both sides of the workpiece and saw through this sandwich.

SAWING METAL

- Be aware that sawing metal takes much more time than sawing wood.
- Use a saw blade suitable for sawing metal.
- When cutting thin metal, clamp a piece of scrap wood to the back surface of the workpiece and cut through this sandwich.
- Spread a film of oil along the intended line of cut for easier operation and longer blade life. For cutting aluminum, kerosene is preferred.

Rip/Circle Cutting (fig. 7, 8)

Ripping and circle cutting without a pencil line are easily done with the rip fence / circle guide (not included; available at extra cost).

Using the screw supplied with the accessory guide, position as shown in figure 7 and thread the screw into the shoe to clamp the fence securely.

When ripping, position as shown in figure 7 and slide the rip fence under the screw from either side of the saw. Set the cross bar (j) at desired distance from blade and tighten screw. For ripping, the cross bar should be down and against the straight edge of the workpiece as shown.

When circle cutting, adjust rip fence so that distance from blade to hole in fence arm (k) is at the desired radius and tighten screw. Place saw so that hole in fence arm is over center of circle to be cut (drill hole for blade or cut inward from edge of material to get blade into position). When saw is properly positioned, drive a small nail through hole in fence arm. Using rip fence as a pivot arm, begin cutting circle. For circle cutting, the cross bar should be up, as shown in figure 8.

MAINTENANCE

Your DEWALT power tool has been designed to operate over a long period of time with a minimum of maintenance. Continuous satisfactory operation depends upon proper tool care and regular cleaning.

- Regularly clean the ventilation slots in your tool using a soft brush or dry cloth.
- Regularly clean the motor housing using a damp cloth. Do not use any abrasive or solvent-based cleaner.



Lubrication

Your power tool requires no additional lubrication.



Cleaning



WARNING: Blow dirt and dust out of the main housing with dry air as often as dirt is seen collecting in and around the air vents. Wear approved eye protection and approved dust mask when performing this procedure.



WARNING: Never use solvents or other harsh chemicals for cleaning the non-metallic parts of the tool. These chemicals may weaken the materials used in these parts. Use a cloth dampened only with water and mild soap. Never let any liquid get inside the tool; never immerse any part of the tool into a liquid.

Optional Accessories



WARNING: Since accessories, other than those offered by DEWALT, have not been tested with this product, use of such accessories with this tool could be hazardous. To reduce the risk of injury, only DEWALT, recommended accessories should be used with this product.

Consult your dealer for further information on the appropriate accessories.

Protecting the Environment



Separate collection. This product must not be disposed of with normal household waste.

Should you find one day that your DEWALT product needs replacement, or if it is of no further use to you, do not dispose of it with household waste. Make this product available for separate collection.



Separate collection of used products and packaging allows materials to be recycled and used again. Re-use of recycled materials helps prevent environmental pollution and reduces the demand for raw materials.

Local regulations may provide for separate collection of electrical products from the household, at

municipal waste sites or by the retailer when you purchase a new product.

DEWALT provides a facility for the collection and recycling of DEWALT products once they have reached the end of their working life. To take advantage of this service please return your product to any authorised repair agent who will collect them on our behalf.

You can check the location of your nearest authorised repair agent by contacting your local DEWALT office at the address indicated in this manual. Alternatively, a list of authorised DEWALT repair agents and full details of our after-sales service and contacts are available on the Internet at: www.2helpU.com

