

STANLEY®

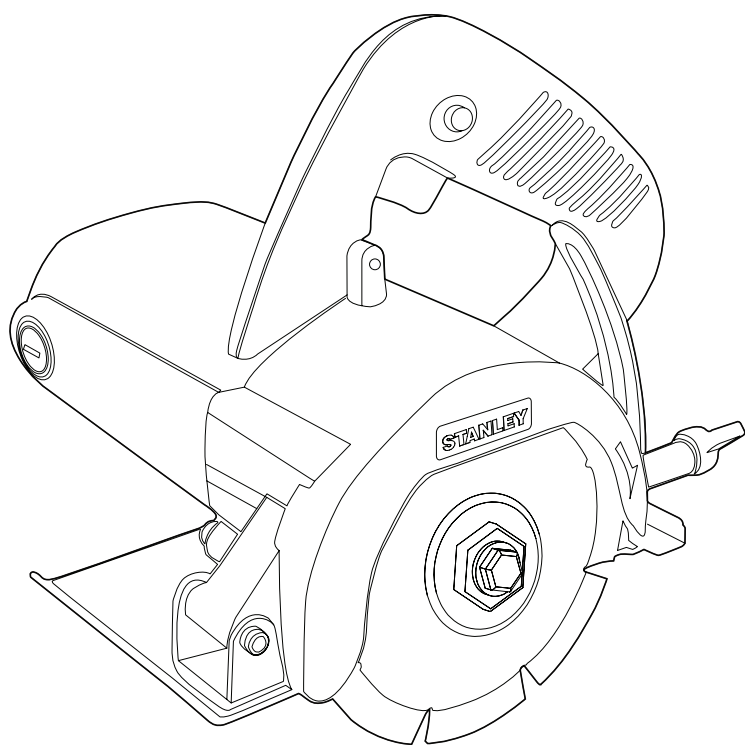

STSP110

English

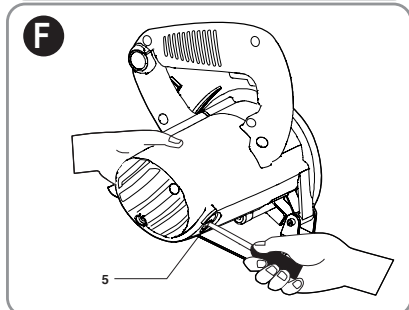
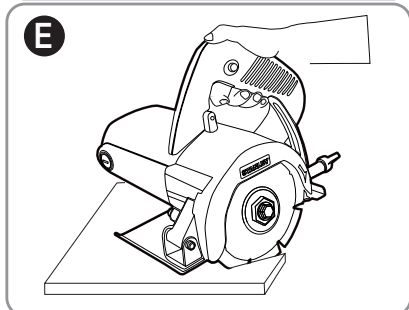
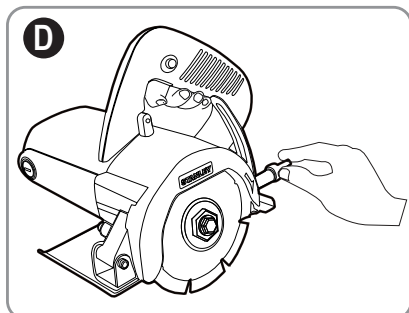
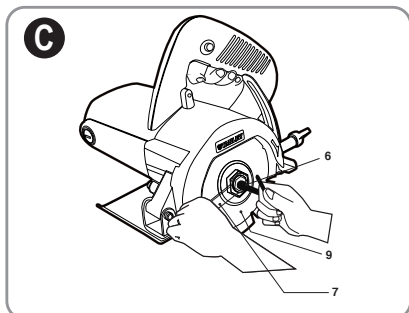
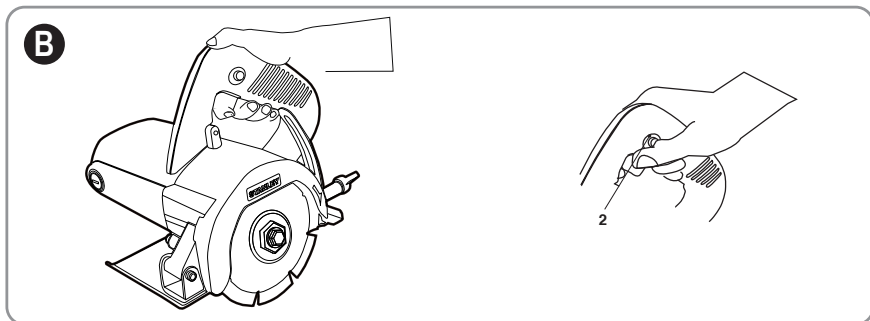
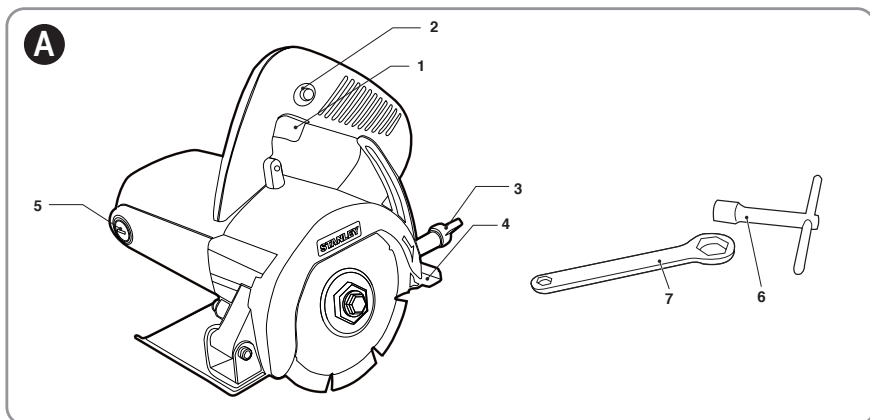

INTENDED USE

Your STANLEY Tile Cutter STSP110 have been designed for cutting tiles and marbles using the appropriate type of disc. These tools are intended for professional use.

SAFETY INSTRUCTIONS

The definitions below describe the level of severity for each signal word. Please read the manual and pay attention to these symbols.



DANGER: Indicates an imminently hazardous situation which, if not avoided, **will result in death or serious injury.**



WARNING: Indicates a potentially hazardous situation which, if not avoided, **could result in death or serious injury.**



CAUTION: Indicates a potentially hazardous situation which, if not avoided, **may result in minor or moderate injury.**

NOTICE: Indicates a practice not related to personal injury which, if not avoided, **may result in property damage.**



Denotes risk of electric shock.



Denotes risk of fire.



Warning: To reduce the risk of injury, read the instruction manual.

General power tool safety warnings



WARNING! Read all safety warnings, instructions, illustrations and specifications provided with this power tool. Failure to follow all instructions listed below may result in electric shock, fire and/or serious injury.

Save all warnings and instructions for future reference.

The term "power tool" in the warnings refers to your mains-operated (corded) power tool or battery-operated (cordless) power tool.

1. Work area safety

- Keep work area clean and well lit.** Cluttered or dark areas invite accidents.
- Do not operate power tools in explosive atmospheres, such as in the presence of flammable liquids, gases or dust.** Power tools create sparks which may ignite the dust or fumes.
- Keep children and bystanders away while operating a power tool.** Distractions can cause you to lose control.

2. Electrical safety

- Power tool plugs must match the outlet. Never modify the plug in any way. Do not use any adapter plugs with earthed (grounded) power tools.** Unmodified plugs and matching outlets will reduce risk of electric shock.
- Avoid body contact with earthed or grounded surfaces such as pipes, radiators, ranges and refrigerators.** There is an increased risk of electric

shock if your body is earthed or grounded.

- Do not expose power tools to rain or wet conditions.** Water entering a power tool will increase the risk of electric shock.
 - Do not abuse the cord. Never use the cord for carrying, pulling or unplugging the power tool. Keep cord away from heat, oil, sharp edges or moving parts.** Damaged or entangled cords increase the risk of electric shock.
 - When operating a power tool outdoors, use an extension cord suitable for outdoor use.** Use of a cord suitable for outdoor use reduces the risk of electric shock.
 - If operating a power tool in a damp location is unavoidable, use a residual current device (RCD) protected supply.** Use of an RCD reduces the risk of electric shock.
- Personal safety**
 - Stay alert, watch what you are doing and use common sense when operating a power tool. Do not use a power tool while you are tired or under the influence of drugs, alcohol or medication.** A moment of inattention while operating power tools may result in serious personal injury.
 - Use personal protective equipment. Always wear eye protection.** Protective equipment such as a dust mask, non-skid safety shoes, hard hat, or hearing protection used for appropriate conditions will reduce personal injuries.
 - Prevent unintentional starting. Ensure the switch is in the off-position before connecting to power source and/or battery pack, picking up or carrying the tool.** Carrying power tools with your finger on the switch or energising power tools that have the switch on invites accidents.
 - Remove any adjusting key or wrench before turning the power tool on.** A wrench or a key left attached to a rotating part of the power tool may result in personal injury.
 - Do not overreach. Keep proper footing and balance at all times.** This enables better control of the power tool in unexpected situations.
 - Dress properly. Do not wear loose clothing or jewellery. Keep your hair and clothing away from moving parts.** Loose clothes, jewellery or long hair can be caught in moving parts.
 - If devices are provided for the connection of dust extraction and collection facilities, ensure these are connected and properly used.** Use of dust collection can reduce dust-related hazards.
 - Do not let familiarity gained from frequent use of tools allow you to become complacent and ignore tool safety principles.** A careless action can cause severe injury within a fraction of a second.
 - Power tool use and care**
 - Do not force the power tool. Use the correct power tool for your application.** The correct power tool will do the job better and safer at the rate for which it was designed.
 - Do not use the power tool if the switch does not**

turn it on and off. Any power tool that cannot be controlled with the switch is dangerous and must be repaired.

- c. **Disconnect the plug from the power source and/ or remove the battery pack, if detachable from the power tool before making any adjustments, changing accessories, or storing power tools.** Such preventive safety measures reduce the risk of starting the power tool accidentally.
 - d. **Store idle power tools out of the reach of children and do not allow persons unfamiliar with the power tool or these instructions to operate the power tool.** Power tools are dangerous in the hands of untrained users.
 - e. **Maintain power tools and accessories. Check for misalignment or binding of moving parts, breakage of parts and any other condition that may affect the power tools operation. If damaged, have the power tool repaired before use.** Many accidents are caused by poorly maintained power tools.
 - f. **Keep cutting tools sharp and clean.** Properly maintained cutting tools with sharp cutting edges are less likely to bind and are easier to control.
 - g. **Use the power tool, accessories and tool bits etc. in accordance with these instructions, taking into account the working conditions and the work to be performed.** Use of the power tool for operations different from those intended could result in a hazardous situation.
 - h. **Keep handles and grasping surfaces dry, clean and free from oil and grease.** Slippery handles and grasping surfaces do not allow for safe handling and control of the tool in unexpected situations.
- 5. Service**
- a. **Have your power tool serviced by a qualified repair person using only identical replacement parts.** This will ensure that the safety of the power tool is maintained.

ADDITIONAL SPECIFIC SAFETY RULES

SAFETY INSTRUCTIONS FOR ALL OPERATIONS

Safety instructions for cutting-off operations Cut-off machine safety warnings.

- a. **The guard provided with the tool must be securely attached to the power tool and positioned for maximum safety, so the least amount of wheel is exposed towards the operator. Position yourself and bystanders away from the plane of the rotating wheel.** The guard helps to protect operator from broken wheel fragments and accidental contact with wheel.
- b. **Use only diamond cut-off wheels for your power tool.** Just because an accessory can be attached to your power tool, it does not assure safe operation.
NOTE: Use the wording "diamond" as applicable depending on the designation of the tool.
- c. **The rated speed of the accessory must be at least equal to the maximum speed marked on the power tool.** Accessories running faster than their rated speed can break and fly apart.
- d. **Wheels must be used only for recommended applications.** For example: do not grind with the side of cut-off wheel. Cut-off wheels are intended

for peripheral grinding, side forces applied to these wheels may cause them to shatter.

- e. **Always use undamaged wheel flanges that are of correct diameter for your selected wheel.** Proper wheel flanges support the wheel thus reducing the possibility of wheel breakage.
 - f. **Do not use worn down reinforced wheels from larger power tools.** Wheels intended for a larger power tool are not suitable for the higher speed of a smaller tool and may burst.
- NOTE: The above warning does not apply for tools only designated to be used with diamond wheels.
- g. **The outside diameter and the thickness of your accessory must be within the capacity rating of your power tool.** Incorrectly sized accessories cannot be adequately guarded or controlled.
 - h. **The arbour size of wheels and flanges must properly fit the spindle of the power tool.** Wheels and flanges with arbour holes that do not match the mounting hardware of the power tool will run out of balance, vibrate excessively and may cause loss of control.
 - i. **Do not use damaged wheels. Before each use, inspect the wheels for chips and cracks. If power tool or wheel is dropped, inspect for damage or install an undamaged wheel. After inspecting and installing the wheel, position yourself and bystanders away from the plane of the rotating wheel and run the power tool at maximum no load speed for one minute.**

Damaged wheels will normally break apart during this test time.

- j. **Wear personal protective equipment. Depending on application, use face shield, safety goggles or safety glasses. As appropriate, wear dust mask, hearing protectors, gloves and shop apron capable of stopping small abrasive or workpiece fragments.** The eye protection must be capable of stopping flying debris generated by various operations. The dust mask or respirator must be capable of filtrating particles generated by your operation. Prolonged exposure to high intensity noise may cause hearing loss.
- k. **Keep bystanders a safe distance away from work area. Anyone entering the work area must wear personal protective equipment.** Fragments of workpiece or of a broken wheel may fly away and cause injury beyond immediate area of operation.
- l. **Hold the power tool by insulated gripping surfaces only, when performing an operation where the cutting accessory may contact hidden wiring or its own cord.** Cutting accessory contacting a "live" wire may make exposed metal parts of the power tool "live" and could give the operator an electric shock.
- m. **Position the cord clear of the spinning accessory.** If you lose control, the cord may be cut or snagged and your hand or arm may be pulled into the spinning wheel.
- n. **Never lay the power tool down until the accessory has come to a complete stop.** The spinning wheel may grab the surface and pull the power tool out of your control.
- o. **Do not run the power tool while carrying it at your side.** Accidental contact with the spinning accessory

could snag your clothing, pulling the accessory into your body.

- p. **Regularly clean the power tool's air vents.** The motor's fan will draw the dust inside the housing and excessive accumulation of powdered metal may cause electrical hazards.
- q. **Do not operate the power tool near flammable materials.** Sparks could ignite these materials.
- r. **Do not use accessories that require liquid coolants.** Using water or other liquid coolants may result in electrocution or shock.

NOTE: The above warning does not apply for power tools specifically designed for use with a liquid system.

ADDITIONAL SAFETY PRECAUTIONS FOR MARBLE CUTTERS

 **Caution!** Do not touch exposed metal parts of the tool when cutting through walls and floors, or when in contact with electrical wiring! Hold the tool by insulated gripping surfaces when performing an operation where the cutting tool may come in contact with concealed wiring or its own cord. Contact with a "live" wire will make exposed metal parts of the tool "live" and this will cause electric shock to the operator.

1. **Always keep your hands away from the cutting area and the diamond wheel. Always keep the other hand on the side handle.** If you hold the tool with both hands, you will not be injured by the wheel.
2. **Do not touch the underside of the workpiece** because the guard cannot protect the part of the wheel under the workpiece.
3. **Always use a diamond wheel with well-matched size and center (diamond or circular shape).** Mismatched wheel and holder will result in eccentric operation and you may lose control.
4. **Do not use any washer or bolt that is damaged or unfit in size;** otherwise you will lose control of the operation.
5. **Do not use any grinding wheel.**
6. **Do not use any diamond wheel that does not conform to the manufacturer's stipulations.**
7. **Do not use any cutting wheel that has been damaged, distorted, or cracked.**
8. **Do not operate the tool without the fixed guard.**
9. **Do not start the tool with the cutting wheel touching the workpiece.**
10. **After switching off the tool, put down the tool only after the cutting wheel has completely stopped running. Do not force the wheel to stop.**
11. Disconnect the plug from the power source and ensure that the diamond wheel is stationary before replacing it, adjusting the cutting depth or water pipe, or repairing the tool.
12. **Only hold the tool by its insulated gripping surface when the diamond wheel is likely to cut through concealed wires or its own cord.** If the diamond wheel touches a "live" wire, the exposed metal parts of the power tool may be charged and thus cause electric shock to the operator.
13. **Be extra cautious when "blind cutting" through walls or other blind areas** because the diamond wheel may cut into gas or water piping, wires, or resilient objects.

PERSONAL SAFETY

- No children or pregnant women should enter the work area where the paint sanding is being done until all cleanup is completed.
- A dust mask or respirator should be worn by all persons entering the work area. The filter should be replaced daily or whenever the wearer has difficulty breathing.

NOTE: only those dust masks suitable for working with lead paint dust and fumes should be used. Ordinary painting masks do not offer this protection. See your local hardware dealer for the NIOSH approved proper mask.

ENVIRONMENTAL SAFETY

- Paint should be removed in such a manner as to minimize the amount of dust generated.
- Areas where paint removal is occurring should be sealed with plastic sheeting of 4 mils thickness.
- Sanding should be done in a manner to reduce tracking of paint dust outside the work area.

RESIDUAL RISKS

In spite of the application of the relevant safety regulations and the implementation of safety devices, certain residual risks cannot be avoided. These are:

- Impairment of hearing
- Risk of personal injury due flying particles.
- Risk of burns due to accessories becoming hot during operation.
- Risk of personal injury due to prolonged use.
- Risk of dust from hazardous substances.

ELECTRICAL SAFETY



Your tool is double insulated; therefore no earth wire is required. Always check that the main voltage corresponds to the voltage on the rating plate.



WARNING! If the power cord is damaged, it must be replaced by the manufacturer, authorized STANLEY Service Center or an equally qualified person in order to avoid damage or injury. If the power cord is replaced by an equally qualified person, but not authorized by STANLEY, the warranty will not be valid.

USING AN EXTENSION CABLE

If it is necessary to use an extension cable, please use an approved extension cable that fits the tool's power input specifications. The minimum cross-sectional area of the conducting wire is 1.5 sq. mm. Cables should be untangled before reeling up.

Cable cross-sectional area (mm ²)	Cable rated current (Ampere)
0.75	6
1.00	10
1.50	15
2.50	20

4.00	25
------	----

Cable length (m)						
	7.5	15	25	30	45	60

Voltage	Amperes	Cable rated current (Ampere)					
110-127	0 - 2.0	6	6	6	6	6	10
	2.1 - 3.4	6	6	6	6	15	15
	3.5 - 5.0	6	6	10	15	20	20
	5.1 - 7.0	10	10	15	20	20	25
	7.1 - 12.0	15	15	20	25	25	-
220-240	12.1 - 20.0	20	20	25	-	-	-
	0 - 2.0	6	6	6	6	6	6
	2.1 - 3.4	6	6	6	6	6	6
	3.5 - 5.0	6	6	6	6	10	15
	5.1 - 7.0	10	10	10	10	15	15
	7.1 - 12.0	15	15	15	15	20	20
	12.1 - 20.0	20	20	20	20	25	-

LABELS ON TOOL

The label on your tool may include the following symbols:

	WARNING! To reduce the risk of injury, the user must read the instruction manual before use.		
	Wear safety glasses or goggles.		
	Wear ear protection.		
	Wear a dust mask.		
V	Volts		Direct Current
A	Amperes	n_0	No-Load Speed
Hz	Hertz		Class II Construction
W	Watts		Earthing Terminal
min	minutes		Safety Alert Symbol
	Alternating Current	/min.	Revolutions or Reciprocation per minute

Position of date code

The Date Code, which also includes the year of manufacture, is printed into the housing.

Example:

2020 XX JN
Year of manufacturing

PACKAGE CONTAINS

The package contains:

- 1 Tile Cutter
- 1 Socket Wrench
- 1 Spanner
- 1 Instruction manual
- Check for damage to the tool, parts or accessories which may have occurred during transport.
- Take the time to thoroughly read and understand this manual prior to operation.

FEATURES (Fig A)



WARNING: Never modify the power tool or any part of the tool, otherwise it may cause damage to the tool or result in personal injury.

1. ON/OFF Switch
2. Lock-on button
3. Butterfly screw
4. Base
5. Brush cap
6. Socket wrench
7. Spanner

ASSEMBLY



WARNING: To prevent accidental operation, turn off and unplug tool before performing the following operations. Failure to do this could result in serious personal injury.

Installing & Removing the Diamond Wheel (Fig. C)



WARNING: To minimize the danger of serious personal injury, please switch off the tool power and disconnect all plugs before adjusting or removing/installing any accessory. Before reassembling the tool, press and release the trigger switch to make sure the tool is already switched off.

Installation

Grip outside flange with spanner (7) and turn the screw counterclockwise with the socket wrench (6).

Be sure to tighten clamp blot securely.

Use only the recommended diamond wheel with the correct hole size.

Removing

Follow the procedures above in reverse order.

Cutting Depth Adjustment (Fig. D)

- To increase or decrease the depth of cut, loosen the butterfly screw (3), move the base (4) to adjust the depth,

and tighten the screw to secure the depth.

- To prevent tool fault, the depth-of-cut adjustment knob has been set to the optimal position at factory default.
- Users may also set the knob to a desired position at any time.

Preparation before use

- Always observe the safety instructions and applicable regulations.
- Ensure that the butterfly screw (3) is properly tightened before operating the tool.

Switching On And Off (Fig. B)

To switch the tool on, press the on/off switch (1).

To switch the tool off, release the on/off switch.

This tool has a lock-on feature. To activate, press the on/off switch and then the lock-on button (2). To de-activate, press the on/off button again.

Always switch off the tool and then the power supply when work is finished.

Cutting (Fig. E)

Align the front edge of the base with the cutting line on the workpiece. Hold the tool firmly. Set the base on the workpiece to be cut without the wheel making any contact.

Turn the tool on and wait until the wheel attains full speed.

Move the tool forward over the workpiece surface, advancing smoothly until the cut is completed.

Keep the cutting line straight.

This tool should only be used on horizontal surfaces.

Be sure to move the tool gently forward, in a straight line. Forcing, or exerting excessive pressure, or allowing the wheel to bend, pinch or twist in the cut can cause the motor to over heat and tool to kick back dangerously.

When the depth of cut is over 20mm deep, make 2 or 3 separate cuts to prevent motor failure.

MAINTENANCE

Your STANLEY tool has been designed to operate over a long period of time with a minimum of maintenance. Continuous satisfactory operation depends upon proper tool care and regular cleaning.



WARNING! To minimize the danger of serious personal injury, please switch off the tool power and disconnect all plugs before adjusting or removing/ installing any accessory. Before reassembling the tool, press and release the trigger switch to make sure the tool is already switched off.



WARNING! Before performing any maintenance on corded/ cordless power tools:

Carbon Brushes (Fig. F)

Remove and check carbon brushes regularly. Replace when they have worn down to about 6mm or less.

Keep carbon brushes clean for free movement in the holder. Both carbon brushes should be replaced at the same time.

Use only Stanley carbon brushes.

Use a slotted screwdriver to remove brush caps (5). Remove worn brushes, insert new ones, and secure the brush caps.



Lubrication

STANLEY tools are properly lubricated at the factory and are ready for use.

Tools should be lubricated regularly every year depending on usage. (Tools used on heavy duty jobs and tools exposed to heat may require more frequent lubrication.) This lubrication should be attempted only by trained power tool repairperson's such as those at STANLEY service centers or in other qualified service personnel.



Cleaning



WARNING! Dust and grit from metal grinding often accumulate on interior surfaces and could create an electrical shock hazard if not cleaned out. Use only mild soap and a damp cloth to clean the tool. Never let any liquid get inside the tool; never immerse any part of the tool into a liquid.



WARNING! Never use solvents or harsh chemicals to clean non-metal parts of the tool. These chemicals may weaken the material of the parts. Use only mild soap and damp cloth to clean the tool. Never let any liquid get inside the tool; never immerse any part of the tool into liquid.



WARNING! Do not overload your angle grinder. Overloading causes a reduction in speed and efficiency, causing your angle grinder to become too hot. If this happens, operate your angle grinder under no load for one or two minutes until it has cooled to normal operating temperature. Switching your angle grinder off under load will reduce the life of the switch.



IMPORTANT! To ensure product SAFETY and RELIABILITY, repairs, maintenance and adjustment (other than those listed in this manual) should be performed by authorized service centers or other qualified organizations, always using identical replacement parts. Unit contains no user service able parts inside.

ACCESSORIES



WARNING: Since accessories, other than those offered by STANLEY, have not been tested with this product, use of such accessories with this tool could be hazardous. To reduce the risk of injury, only STANLEY, recommended accessories should be used with this product.

The performance of any power tool is dependent upon the accessory used. STANLEY accessories are engineered to high quality standards and are designed to enhance the performance of power tool. By using STANLEY accessories will ensure that you get the very best from your STANLEY tool. STANLEY offers a large selection of accessories available at our local dealer or authorized service center at extra cost.

PROTECTING THE ENVIRONMENT



Separate collection. This product must not be disposed of with normal household waste.

Should you find one day that your STANLEY product needs replacement, or if it is of no further use to you, do not dispose of it with household waste. Make this product available for separate collection.



STANLEY provides a facility for the collection and recycling of STANLEY products once they have reached the end of their working life. To take advantage of this service please return your product to any authorised repair agent who will collect them on our behalf.

You can check the location of your nearest authorised repair agent by contacting your local STANLEY office at the address indicated in this manual. Alternatively, a list of authorised STANLEY repair agents and full details of our after-sales service and contacts are available on the Internet at: www.2helpU.com.

NOTES

STANLEY's policy is one of continuous improvement to our products and as such, we reserve the right to change product specifications without prior notice. Standard equipment and accessories may vary by country. Product specifications may differ by country. Complete product range may not be available in all countries. Contact your local STANLEY dealers for range availability

SERVICE INFORMATION

STANLEY offers a full network of company-owned and authorized service locations. All STANLEY Service Centers are staffed with trained personnel to provide customers with efficient and reliable power tool service. For more information about our authorized service centers and if you need technical advice, repair, or genuine factory replacement parts, contact the STANLEY location nearest you.

TECHNICAL DATA

Tile Cutter		STSP110
Voltage	V _{AC}	220-240
Frequency	Hz	50/60
Input power	W	1200
No-load speed	min ⁻¹	13000
Max Cutting Wheel	mm	34
Blade diameter		110
Weight	kg	3.1