

0 611 269 0F0 – GBH 5-40 D

Material number	0 611 269 0F0
EAN	4059952567648



Technical data

Description

Long version part 1 (BE)

The GBH 5-40 D Professional is the entry-level tool in Bosch's SDS max corded rotary hammer category. Its lightweight and compact design makes it ideal for work in hard-to-reach places. The rotary hammer is also designed for durability, featuring robust metal components and an optimised lubrication system. Its strong motor enables the delivery of 8.5 J of impact energy for a fast drilling progress and high material removal rate.



Noise level

The A-rated noise level of the power tool is typically as follows: Sound pressure level 93.5 dB(A); Sound power level 104.5 dB(A). Uncertainty K= 3 dB.

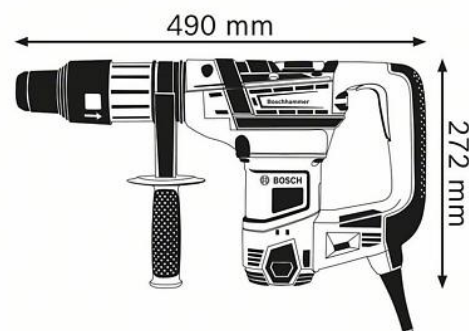

Technical data

Rated input power	1.100 W
Impact energy (according to EPTA 05/2016)	8.5 J
Impact rate at rated speed	1,500 – 2,900 bpm
Rated speed	170 – 340 rpm
Weight	6,8 kg
Tool holder	SDS max

Drilling range

Hammer drilling diameter range in concrete	12 – 40 mm
Recommended drilling diameter range in concrete	18 – 32 mm
Drilling dia. concrete, breakthrough drill bits	45 – 55 mm
Drilling diameter in concrete with core cutters	40 – 90 mm



Sales information

Positioning

- The powerful hammer with fastest drilling progress in its class

User benefit

- Fastest drilling progress – 30% faster than its predecessor
- High material removal rate – 50% more impact energy than existing GBH 5-38 D
- Perfect handling – well balanced tool for all applications

